

Discovery Hybrid Rheometer



Site Preparation Guide for HR 10/20/30 Series

Table of Contents

Table of Contents	2
Ideal Setup.....	3
System Components.....	4
Instrument Measurements.....	5
Utility Requirements	6
Power	6
Gas.....	7
Circulating Fluid.....	7
Computer Requirements.....	8–9
Hardware.....	8
Software	9
Site Preparation Checklist	10
TA Instrument Offices.....	11



Circulator



Power



Cooling



Gas



LN₂



Fluid



Light



Hardware



Software



Temp



Lab



Customer

Ideal Setup



IDEAL PLACEMENT AND BENCH MEASUREMENTS

Select a location with adequate floor space and a rigid laboratory bench that is level and is in a vibration-free environment. A marble table is recommended.

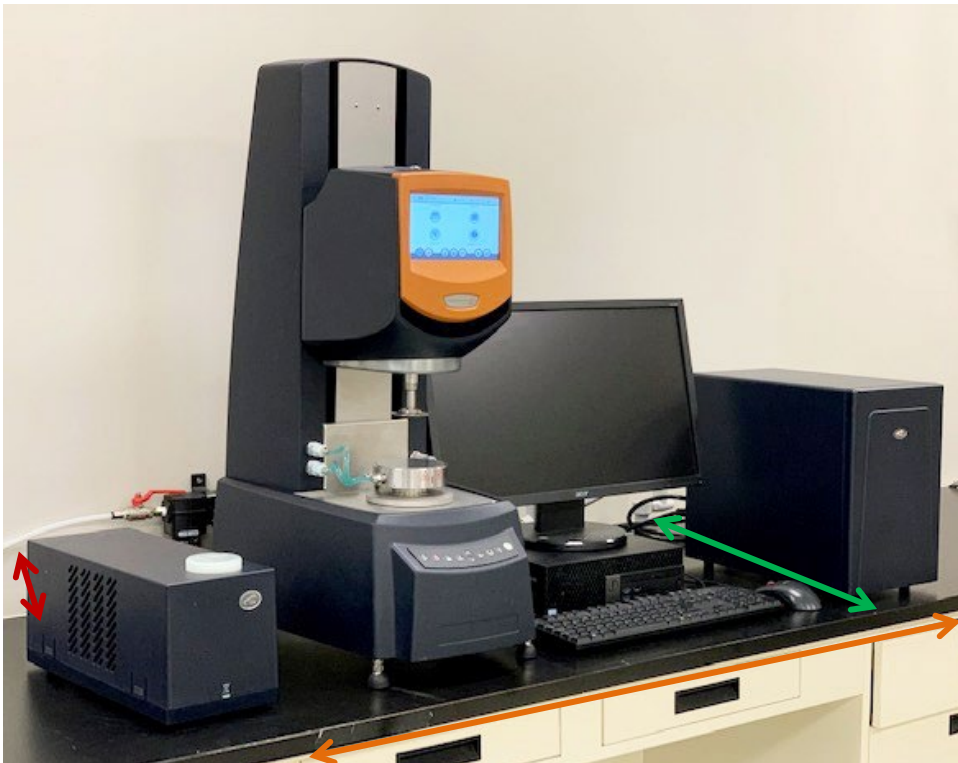

Bench width: 127 cm (50 in)

Marble table width: 60 cm (24 in)

Bench depth: 76 cm (30 in)

Marble table depth: 76 cm (30 in)

Distance from the wall: 30.5 cm (12 in) min.

System Components



MAIN SYSTEM COMPONENTS



- A. Instrument
- B. Computer
- C. Electronics Control Module

Instrument Measurements



MAIN INSTRUMENT



Height: 91 cm (35.8 in)

Width: 34 cm (13.4 in)

Depth: 48 cm (18.5 in)

Weight: 42.4 kg (93.5 lbs)



ELECTRONICS CONTROL MODULE

Height: 36 cm (14.2 in)

Width: 23 cm (9 in)

Depth: 40 cm (15.7 in)



Weight: 10.7 kg (23.6 lbs)



Utility Requirements

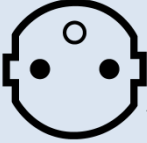

POWER

Item	Requirement
Power	<ul style="list-style-type: none">• 110–240 VAC, 47–63 Hz, 1.4 kW• Neutral to Ground (NG) voltage max 0.5 volt• Safety ground per local regulation
Power cords provided	<ul style="list-style-type: none">• NEMA 5-15 plug• Type F plug  Type F  NEMA 5-15



Use power cords with plugs appropriate for your circuit.



Supply voltages lower than indicated may result in a degradation of performance.



Ensure that the mains assigned do not also supply power to noise generating equipment nearby, such as motors, welders, transformers, etc.



An independent heavy GROUND wire must be provided through the power hookup. Improper grounding may cause severe damage for which the supplier will not accept responsibility. All power strips must be fully grounded and carry the ground through to the sockets into which the computer is plugged.

Utility Requirements



GAS

Air Bearing (Air or Nitrogen):

Gas Pressure	Compressed at 482–1034 kPa gauge (70–150 psig)
Flow Rate	Air flow volume capacity requirements are specific to the Temp Control Options purchased with the DHR instrument. Refer to the DHR Accessories Site Prep Guide for additional information.
Dew point	-20°C or better
Conditions	<ul style="list-style-type: none">• Must be dry• Must be free from oil and dirt¹
Other	<ul style="list-style-type: none">• ¼ NPT female connection required for DHR main air supply (not provided)

¹Compressed Air Quality Requirements

Dew point	Ideal: -40°C Minimum: -20°C
Dirt particle	5µm
Oil including vapor	0.01 mg/m ³



CIRCULATING FLUID

Item	Requirement
Circulating Fluid	See the HR/DHR Accessories Requirements for specific fluid requirements.

Computer Requirements



HARDWARE REQUIREMENTS

Description	Requirement
Processor	<ul style="list-style-type: none">• Intel® Core™ i5 8400 or better• 2.8 GHz with 9 MB L2 cache
Memory	≥ 16 GB RAM DDR4 2666 SDRAM
Hard drive	≥ 80 GB free space <ul style="list-style-type: none">• 1.5 GB required for Full version of TRIOS• 675 MB required for Lite version of TRIOS (without Online help)
DVD (optional)	≥ 48x CD-ROM or DVD (optional for installing TRIOS)
Screen resolution	Required: 1280 x 1024 with 24-bit colors Recommended: 1920 x 1080 with 24-bit colors
Graphic memory	128 MB
Screen (LCD) size	Required: 19" or greater Recommended: 24" wide screen
USB II port	Required with ETC and Peltier Camera Viewer options, SALS accessory, and Automatic Asphalt calibration kit
Network card	Ethernet 10Base T/100 Base TX
Additional Ethernet card(s)	Necessary if connecting the instrument directly and access is needed to the Corporate LAN. Also required for Modular Microscope Accessory.
Ethernet Cabling	10/100BaseTX Ethernet hub/switch. Must be EIA-568B Category 5+ UTP
Client-Server Protocol	DHCP
Image Capture (Camera Option)	DirectX 9.0 or higher
Second Monitor	Recommended for SALS Accessory image viewing and Modular Microscope Accessory
TCP/IP ports used	<ul style="list-style-type: none">• TCP: 20010, 20011• UDP: 5050, 5056

Computer Requirements







SOFTWARE REQUIREMENTS

Item	TRIOS
Operating System	<ul style="list-style-type: none">• Windows 10 or 11 Ultimate & Professional• Home version not supported• ≥ 64-bit version
Internet	Internet connection is strongly recommended for ongoing support after installation
Service Pack	Microsoft Operating System Service Pack
Updates	Windows Operating System and associated Microsoft updates must be up to date
Network	<i>A second network card for corporate connection is recommended. TA Instruments is not responsible for resolving issues associated with connections to your corporate network.</i>
Conflicts	<i>TA Instruments is not responsible for resolving hardware/software conflicts created by the addition of third-party hardware or software to the computer.</i>

Site Preparation Checklist



Discovery Hybrid Rheometer – HR 10/20/30 Series

	<p>Enough bench space for instrument, computer, and Electronics Control Box</p> <ul style="list-style-type: none"> <input type="checkbox"/> Bench length: 127 cm (50 in) <input type="checkbox"/> Bench depth: 76 cm (30 in)
	<p>Instrument power is 110–230 VAC, 47–63 Hz, 1.4 kW</p>
	<ul style="list-style-type: none"> <input type="checkbox"/> Computer meets all hardware requirements <ul style="list-style-type: none"> <input type="checkbox"/> I have two network cards installed on the computer to be able to connect to both the corporate LAN and the instrument. <input type="checkbox"/> Computer meets all software requirements <input type="checkbox"/> Customer's IT personnel has provided Administrative privileges on the controller computer <input type="checkbox"/> The Customer's IT personnel will be on site the day of installation
	<p>Air Bearing Gas Pressure (air or nitrogen)</p> <ul style="list-style-type: none"> <input type="checkbox"/> Pressure is 482–1034 kPa (70–150 psig) <input type="checkbox"/> Dew point is -20°C or better <input type="checkbox"/> Particle content is < 5µm and oil and vapor is < 0.01 mg/m³ * <input type="checkbox"/> ¼ NPT female connection to the main compressed air source <p>*TA filter/regulator assembly (P/N 250000.001) meets these requirements.</p>
	<ul style="list-style-type: none"> <input type="checkbox"/> The Customer assumes responsibility for any damage that occurs when the instrument is moved by someone other than a trained TA Instruments Service Representative.

I hereby acknowledge that all utility requirements have been met per the checklist above and that they will be ready at the agreed time of installation.

If all utility requirements are not met at the agreed time of installation, additional charges may be incurred for a return Service trip.

Customer *DD* / *MM* / *YYYY*

Company *City* *State* *Country*

Please send a signed copy of the completed checklist to your local Service representative.

TA Instruments Offices

For information on our latest products, contact information, and more, see our website at:
<http://www.tainstruments.com>.

To find your local TA Instruments office and contact information, visit
<http://www.tainstruments.com/contact/ta-directory/>

TA Instruments – Waters LLC
Corporate Headquarters
159 Lukens Drive
New Castle, DE 19720
USA

Telephone: 302-427-4000
Fax: 302-427-4001
Email: info@tainstruments.com