



# *TA Instruments*

## *Installation Requirements for Thermal Analysis/Rheology Systems*

---

Thank you for ordering a Thermal Analysis and/or Rheology system from TA Instruments. To ensure that installation of that system goes as smoothly as possible and has you ready to start evaluating your sample materials as quickly as possible, we are providing the attached installation information. It includes details regarding laboratory space, power, and auxiliary requirements, as well as configuration requirements for the controller (computer). Please review this information carefully and take any appropriate actions prior to the installation date. To avoid unnecessary delays, and/or additional charges, please ensure that the requirements specified in this document are met before your TA Instruments Service Representative arrives. Contact your local TA Instruments Representative if you have any questions.

NOTE: To arrange for installation of your system, contact our U.S. Service Department (302-427-4050) or your local TA Instruments Service Representative.

# Contents

Requirements for the Controller (Computer) .....	3
Free Disk Space Required .....	6
In addition: .....	6
Obtaining Hardcopy System Verification For Windows® 2000 .....	6
Obtaining Hardcopy System Verification For Windows® XP .....	6
Other Software Considerations .....	7
System Configurations .....	7
• Controller Purchased from TA Instruments .....	7
• Software Suite Purchased from TA Instruments .....	7
Requirements for an Advantage Integrity™ System .....	8
Database Server Requirements .....	8
Requirements for the Thermal Analysis Instruments .....	9
Q Series™ Instrument & Accessory Placement .....	9
Q10, Q100 & Q1000 DSC's .....	10
Q10P/PDSC System .....	11
Q50, Q500 TGA's .....	12
Q600 SDT .....	13
Q400 TMA .....	14
Q800 DMA .....	15
Requirements for Miscellaneous Thermal Analysis .....	16
Accessories .....	16
Refrigerated Cooling System (RCS) for use with Q10, Q100 and Q1000 DSC's .....	16
RCS Gas Plumbing Diagram .....	16
Liquid Nitrogen Cooling System (LNCS) for use with Q10, Q100, and Q1000 DSC's .....	17
LNCS Gas Plumbing Diagram .....	18
Finned Air Cooling System (FACS) for use with Q10, Q100, and Q1000 DSC's .....	19
FACS Gas Plumbing Diagram .....	19
Air Compressor Accessory (ACA) for use with DMA Q800 .....	20
Gas Cooling Accessory (GCA) for use with DMA Q800 .....	20
Mechanical Cooling Accessory (MCA) for use with TMA Q400 .....	20
Photocalorimeter Accessory (PCA) for use with DSC Q1000/Q100 .....	21
Liquid Nitrogen Cooling Accessory (LNCA) for use with DEA 2970 .....	21
Requirements for the Rheology Instruments .....	22
AR 2000 Rheometers .....	222
Smart Swap™ Requirements .....	22
AR 550/1000 Rheometers .....	23
QCR and CSA II Rheometers .....	23
Starch Pasting Rheometer .....	23
ARES Rheometer .....	24
ARES Placement .....	24
RSA III Solids Rheometer/DMA .....	25
RSA III Placement .....	25
Requirements for Miscellaneous Rheology Accessories .....	26
Liquid Nitrogen Dewar .....	26
Liquid Nitrogen Controller .....	26
Air Dryer .....	27
Gas Chiller .....	28
Circulator (Julabo FS-18) .....	28
TA Instruments Offices .....	29

Windows® 2000, XP, Microsoft Excel® and Microsoft Word® are registered trademarks of the Microsoft Corporation.

## Requirements for the Controller (Computer)

A working thermal analysis/rheology system consists of one or more measurement modules (*e.g.*, DSC, TGA, AR 2000, ARES) and a computer configured with appropriate TA Instruments software (this latter combination is subsequently referred to as a controller). As a customer, you have two alternatives for configuring a controller. You can either purchase a computer pre-configured by TA Instruments, or you can purchase a suitable computer on your own and configure it at your site. In either case, the general requirements which follow are the same.

**NOTE: In situations where you are supplying the computer, it is assumed that you have reviewed these requirements and suitably prepared the controller prior to the scheduled system installation by the TA Instruments Service Representative. In fact, you will be required to provide hardcopy verification of your system setup using the instructions on page 6 before an installation visit will be scheduled.**

Before installing the TA Instruments software, you should ensure that the computer system meets the following specifications:

**NOTE: Thermal Advantage Instrument Control, Rheology Advantage, Thermal Advantage for Q Series, Universal Analysis, and Advantage Integrity™ may only be installed on Windows® 2000 or Windows® XP Professional. Orchestrator may be installed on Windows® 98, ME, NT, 2000 or XP Professional.**

### Requirements for Windows 2000/XP (Thermal or Rheology Advantage or Orchestrator)

Description	Recommended	Required
Service Packs <ul style="list-style-type: none"> <li>• Windows 2000 Professional</li> <li>• Windows XP Professional</li> </ul>	Service Pack 3 (or higher) Service Pack 1a	Service Pack 2 None
File System	NTFS Required for Thermal Advantage Q Series™ and Advantage Integrity™	
Processor	Intel Pentium III, 1.4 GHz with 256kB L2 cache or better.	
Memory	≥ 256MB RAM	
Hard Drive	≥ 20GB Hard Drive	
CD-ROM	≥ 48X CD-ROM	
Available PCI Slots (Full Size)	2 PCI slots required to run Advantage & Advantage Q Series simultaneously (for GPIB and network cards).	
9-Pin Serial RS 232 Port	One serial port required for each rheometer or RSA III	
USB Port	Required for ARES/RSA III units with Waveform & Fast Data Sampling Option	
Screen Resolution	1024 x 768 with ≥64K colors	
Internet Explorer	V6.0 or higher	V 5.01

### Additional Requirements for Thermal Advantage Q Series™

Description	Requirements
Network Card	3Com or Intel 10/100TX PCI Ethernet NIC for Advantage Q-Series™.
Ethernet Hub/Switch	10BaseT or 10/100BaseTX Ethernet hub/switch for Advantage Q-Series™.
Ethernet Cabling	Must be EIA-568B Category 5 UTP.
Additional Networking Components for Windows® 2000	Network Services, as well as File & Printer Sharing for Microsoft Networks, Client for Microsoft Network, and Internet Protocol (TCP/IP).
TCP/IP Ports	TCP: 5050 UDP: 5050 UDP: 5056

### Additional Requirement for Universal Analysis

Description	Requirement
Support for custom reporting feature of data analysis	Microsoft Word® 97 or higher, Microsoft Excel® 97 or higher, and Adobe Acrobat Reader (provided with Advantage) are also required.

### Additional Requirements for Rheology Advantage

Description	Requirement
Support for custom reporting feature of data analysis and for CSA II	Microsoft Word 97 or higher

### Additional Requirements for Instrument Control Software with Windows® XP

Description	Requirement
User Log-in Capability	While multiple users may still use the "Fast User Switching" function when running Windows XP, only one user at a time may use the TA Instruments Q Series™, Thermal, or Rheology Advantage Instrument Control software. This limit, which is applicable to most programs, is a result of hardware resources that are used by each of these programs.

## Additional Requirements for Orchestrator

**NOTE: PLEASE** check the Port designation (COM1: or COM2: etc..) of the SERIAL Port on which you intend to connect the instrument, as you will need this information to properly Setup the Communication Port for communication with TA Orchestrator Software. **ONLY** Serial Communications to the instrument are supported. Additionally, if you are operating the software on one Host PC with Multiple Instruments (up to 8 instruments can be supported with TA Orchestrator), please note that you will need one Serial Port for each Instrument. If the OAM2 (Optics) option was purchased a serial port must be provided for this option as well.

## Free Disk Space Required

To help you determine which components to install, we have provided the following table containing the approximate amount of free disk space required for installation of the TA Advantage software.

**NOTE: This amount is above that required for the operating system, plus the other software products supplied on the installation CD-ROM. In addition, an extra 15 MB of free disk space is required during the install process (for temporary install files.)**

Software	Instrument Control and Data Analysis	Data Analysis Only	Full Installation
Q Series™	114 MB	13 MB	215 MB (includes all manuals and available languages)
Thermal Advantage™	130 MB (includes manuals)	13 MB	740 MB (includes all videos)
Rheology Advantage	60 MB	—	90 MB (includes all videos)
Orchestrator	60 MB	—	60 MB
Waveform & Fast Data Sampling Option	40 MB	—	40 MB (applies to ARES/RSA III)

### In addition:

- The computer must be an IBM, Dell, Compaq, Hewlett-Packard, Gateway or Micron.
- The computer should be a new computer that is not already attached to other analytical instruments.
- Before the TA Instruments Service Representative will schedule a visit to install new instruments, please obtain a hard copy of the Windows® system summary as instructed below to verify that your system is adequate. Please fax this verification sheet along with your company identification and phone number to TA Instruments Service at 302-427-4054.

### Obtaining Hardcopy System Verification For Windows 2000

- a. Select **Programs/Accessories/System Tools/System Information** from the **Start** menu.
- b. Verify **System Summary** is highlighted.
- c. Press the print button on the tool bar; select to print "Selection."

### Obtaining Hardcopy System Verification For Windows XP

- a. Select **Programs/Accessories/System Tools/System Information** from the **Start** menu.
- b. Verify **System Summary** is highlighted. Note: If you print out this summary from this step you will receive all system information (more than 50 pages). Follow the remaining steps to copy and print only summary information.

- c. Select **Edit/Select All** then **Edit/Copy**.
- d. Open Notepad or another word processing program.
- e. Select **Edit/Paste** then **File/Print**.

## **Other Software Considerations**

- Peripherals (*e.g.*, printer) must be from the known Windows 2000/XP compatible list. (See Microsoft's website at <http://www.microsoft.com/hwtest> for the most current list.)
- TA Instruments is not responsible for resolving issues associated with connections to your corporate network. [See further information in the next section.]
- TA Instruments is not responsible for resolving hardware/software conflicts created by the addition of third party hardware or software to the computer.

## **System Configurations**

TA Instruments 29XX Series thermal analysis modules communicate with the controller via GPIB. Customers who want to upload data to an in-house network for storage or for printing can install an Ethernet card in their computer (all TA Instruments controllers are supplied with an Ethernet card) and can configure it to work with their in-house network.

TA Instruments Q Series™ thermal analysis modules communicate with the controller via TCP/IP. Each TA Instruments controller is supplied with a Ethernet hub/switch for configuring a local network (*i.e.*, controller, module(s), printer).

All TA Instruments Rheometrics Series rheometers (including ARES and AR) communicate with the controller via RS 232.

The ARES/RSA III Waveform & Fast Data Sampling option requires a USB port to communicate with the National Instruments controller.

**If you want to connect a thermal analysis controller with Q Series modules to your in-house network, additional considerations will apply. Review the scenarios shown below for the one that applies to your situation.**

### **• Controller Purchased from TA Instruments**

If you wish to have your TA controller connected to your company network, you must supply a second network interface card. The controller and Q Series modules are shipped with pre-assigned (static) "TA Instruments-compatible" IP addresses. Your MIS department must supply and configure a second Ethernet card for communication with your in-house network. Your TA Instruments serviceman can install this second card during start-up of the system. Note: Using this configuration, you can archive data to another computer on the network or print results on a network printer.

### **• Software Suite Purchased from TA Instruments**

If you wish to have your TA controller connected to your company network you must supply two network interface cards. Your MIS department should configure one of the Ethernet cards in the computer that you are supplying for communication with your in-house network and must supply and install a second card to be used with the TA Q Series™ instruments. Your TA Instruments service representative will configure the second Ethernet card during start-up of the system to communicate with the Q Series modules. Note: Using this configuration, you can archive data to another computer on the network or print results on a network printer.

# Requirements for an Advantage Integrity™ System

An Advantage Integrity system consists of an instrument, a computer for instrument control, and a database server. To obtain installation requirements for the instrument and controller computer, refer to the appropriate sections of this document. The Advantage Integrity systems rely on an Oracle® database installed on a separate database server. This server can operate with the instrument and controller computer as part of a LAN or it can reside on a network. The database server and Oracle software can be purchased from TA Instruments or the customer can supply the server based on the requirements below. Contact TA Instruments Service at 302-427-4050 (U.S.) or your local TA Instruments office for additional information required for the installation of Advantage Integrity systems.

## Database Server Requirements

The following are the requirements for the Advantage Integrity database system:

- **Minimum Hardware Specifications:**
  - ≥ Intel® Pentium® III, 1.0 GHz processor
  - ≥ 512 MB memory
  - ≥ 80 GB hard drive
  - ≥ 24X CD-ROM
  - 3 Com or Intel® 10/100TX PCI Ethernet NIC network card
- **Windows® 2000 Server** software with Service Pack 3 [English language version with English (US) regional settings]
- **Oracle9i Standard Edition** (or Enterprise Edition) database software with the appropriate number of named user licenses. **Global database name and SID must be TAInstDB. Unicode character set must be used.**
- The **Database Server** must be dedicated to the TA Instruments system and not be used as a server for other databases or any other type of servers such as file server, print server, etc.
- Available **DDS/4 Tape Drive** for database back-up.
- Available **database archiving device**. DVD+RW is highly recommended due to its portable format and storage capability. It is not recommended that the selected archive device reside on the database server due to database performance issues during “DVD burning.” Therefore, the archive device must reside on another computer, which has access to the TA database.
- Prior to the installation visit, the customer must install the Oracle® database server on their company network (if a networked configuration is desired) and ensure that the computer is visible on network. **Network connection** must be available in the location where the TA controller will be installed prior to installation. TA Field Service Representative must have access to the appropriate MIS/IT personnel during installation to resolve any networking issues.
- Service installation should not be scheduled until the database server is connected and visible on your company network. Verification of setup will be required. If you are supplying your own controller, then it too must be connected and visible on your company network following the network addressing described in this document.
- Any needed Static IP addresses should be obtained from your IT department and taken out of the company’s list of assignable addresses.



# Requirements for the Thermal Analysis Instruments

The following section summarizes laboratory requirements by instrument. Each section contains all of the requirements for that particular instrument. Therefore, some items will be redundant, if you have purchased a multi-module system.

## Q Series™ Instrument & Accessory Placement

The Q Series base system consists of a controller computer, Q Series instruments, and an optional cooling accessory. For accessory setup information, in addition to that provided here, turn to page 16 of this document.

Select a location for the instrument with adequate floor space and a rigid laboratory bench that is level, has a minimum depth of 76 cm (30 in), and with a length of approximately 183 cm (72 in). Please refer to the layout shown in the figure below and the table at the bottom of the page for component placement.

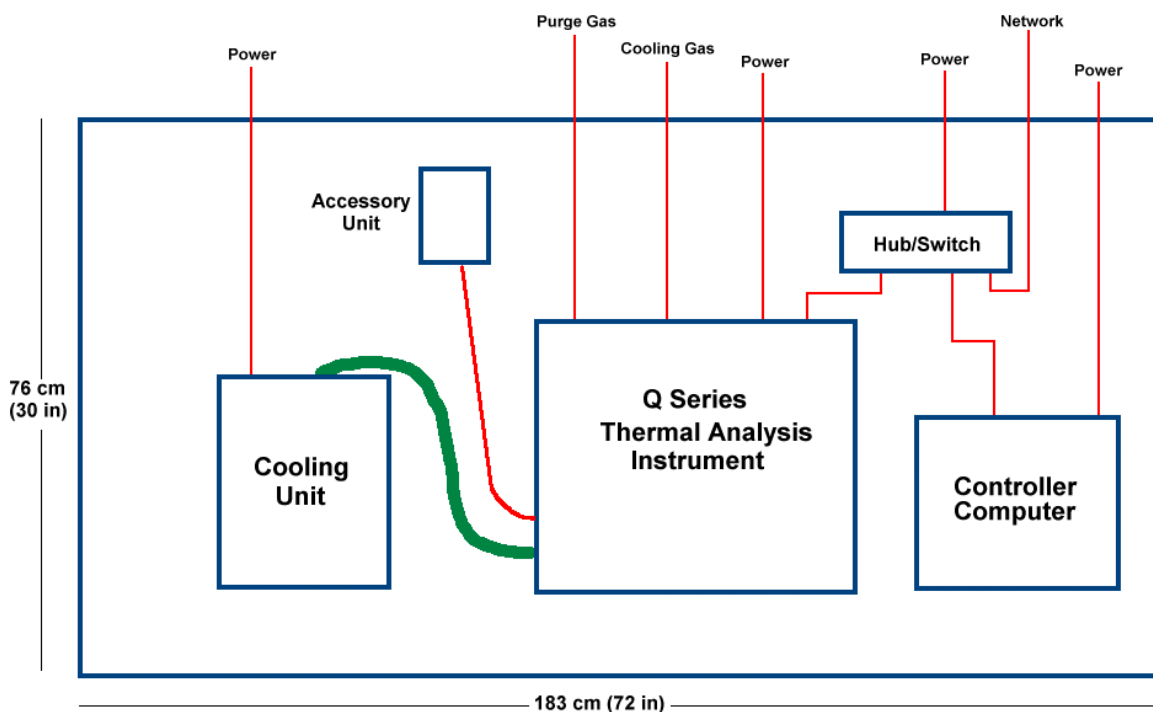

Q Series Instrument	Cooling Unit	Accessory	Location of Cooling Unit/Accessory
DSC Q1000, Q100, Q10	RCS	—	Table
DSC Q1000, Q100, Q10	LNCS	—	Floor
DSC Q1000, Q100	*	PCA	Table
TGA Q500, Q50	—	Heat Exchanger	Table/Floor
SDT Q600	—	—	—
TMA Q400	MCA	—	Table/Floor
DMA Q800	GCA	—	Floor

\* RCS is an optional cooler with PCA in use.

## Q10, Q100 & Q1000 DSC's

Dimensions:	Depth 55.9 cm (22 in), Width 45.7 cm (18 in), Height 41 cm (16 in) - Q10 Depth 55.9 cm (22 in), Width 45.7 cm (18 in), Height 47.8 cm (19 in) - Q100, Q1000
Weight:	24.5 kg (54 lbs.); 8.64 kg (19 lbs) additional for built-in transformer for 230V operation; 4.5 kg (10 lbs) additional for an Autosampler.
Power Requirements:	120 Vac, 47–63 Hz, 500 W [4.5 amps] (Installation Category II) 230 Vac, 47–63 Hz, 500 W [2.25 amps] (Installation Category II) 1.44 kW max with full power delivered through accessory outlets.
Laboratory Conditions:	Temperature 15–35 °C Relative Humidity 5–80% (non-condensing) Instrument should be located in a dust-free, vibration-free environment, away from exposure to direct sunlight and direct air drafts. (Pollution Degree 2 Environment) Maximum Altitude 2000 m (6560 ft)
Laboratory Requirements:	Purge Gas(es) Pressure <sup>(1)(2)</sup> 100–140 kPa gauge (15–20 psig) Cooling Gas (Air) Pressure for use with Finned Air Cooling System <sup>(1)(3)</sup> 170–830 kPa gauge (25-120 psig) Cooling Gas (Nitrogen ) Pressure for use with RCS or LNCS <sup>(1)(3)</sup> 170–830 kPa gauge (25-120 psig) Base Purge Gas Pressure for use with Quench Cooler, RCS or LNCS <sup>(1)(3)</sup> 100–140 kPa gauge (15-20 psig)
<p><sup>(1)</sup> All gases must be dry and free of oil, dirt and water. The Purge Gas and Base Purge Gas are connected to the back of the instrument using 1/8-inch (O.D.) Teflon® tubing and Legris fittings. (Teflon tubing is provided in the DSC accessory kit.) The Cooling Gas is connected to the back of the instrument using ¼ inch (O.D.) Teflon tubing and a Legris fitting. (The fitting at the unit is supplied on the instrument. The ¼ inch tubing and connector at the tank are provided by the customer.) Acceptable cell purge gases include air, nitrogen, oxygen, argon, and helium. Dry nitrogen should be used as the Base Purge gas. Dry nitrogen should also be used as the cooling gas with the RCS and LNCS.</p> <p><sup>(2)</sup> Mass flow controllers (MFC) are a standard feature of the Q1000 and are optional for the Q10 and Q100. Typical purge gas flow rate to the cell is 50 mL/min. If your instrument does not have an MFC, an external flow meter is required.</p> <p><sup>(3)</sup> Actual cooling gas and base purge gas flow rates are controlled by orifices installed in the DSC.</p>	

Teflon® is a registered trademark of E. I. du Pont de Nemours and Company, Wilmington, DE.

Swagelok® is a registered trademark of the Swagelok Corporation, 29500 Solon Road, Solon, Ohio 44139.

Legris is a product of Groupe Legris Industries, Rennes, France.

## Q10P/PDSC System

Dimensions: Q10P PDSC Cell Only	Depth 55.9 cm (22 in), Width 45.7 cm (18 in), Height 41 cm (16 in) Depth 23.6 cm (9.3 in), Width 22.4 cm (8.8 in), Height 33.3 cm (13.1 in)
Weight: Q10P PDSC Cell Only	24.5 kg (54 lbs); 8.64 kg (19 lbs) additional for built-in transformer for 230V operation; 10.5 kg (23 lbs)
Power Requirements:	120 Vac, 47–63 Hz, 350 W [3 amps] (Installation Category II) 230 Vac, 47–63 Hz, 350 W [1.5 amps] (Installation Category II) 1.44 kW max with full power delivered through accessory outlets.
Laboratory Conditions:	Temperature 15–35 °C Relative Humidity 5–80% (non-condensing) Instrument should be located in a dust-free, vibration-free environment, away from exposure to direct sunlight and direct air drafts. (Pollution Degree 2 Environment) Maximum Altitude 2000 m (6560 ft)
Laboratory Requirements:	Q10P DSC — No additional requirements PDSC Cell — Customer-supplied source of clean, dry pressurizing gas (inert, oxidizing, or reducing), and for all accessory regulators, gauges and tubing <sup>(1)</sup> . The gas is usually obtained from a gas supply vendor in approved high-pressure tanks. If the PDSC Cell is to be operated under vacuum conditions, the customer must supply the vacuum source. The cell operating pressure range is from 1 Pa to 7 MPa (0.1 to 1,000 psig). If the PDSC Cell is used in the dynamic or constant pressure mode, and an indication of flow is required, an appropriate external flow meter must be obtained.  Contact TA Instruments for a listing of suitable gases and vacuum suggestions.
<p><sup>(1)</sup> All tubing connecting the PDSC Cell to other devices (<i>e.g.</i>, gas cylinders, gauges, valves, or regulators) should be 31.75-mm (0.125-in) O.D. They must be rated for high pressure service to 21 MPa gauge (3,000 psig) and free of hydrocarbons. The gas source regulator must be rated to withstand the source pressure and possess two gauges—one to monitor the gas source pressure and the second to monitor the regulator output pressure. This should cover the experimental range of the PDSC Cell (up to 7 MPa gauge [1,000 psig]).</p>	

## Q50, Q500 TGA's

Dimensions:	Depth 55.9 cm (22 in), Width 47 cm (18.5 in), Height 52.1 cm (20.5 in) - Q50 & Q500
Weight:	30.9 kg (68 lbs.); 8.18 kg (18 lbs) additional for built-in transformer for 230V operation
Power Requirements:	120 Vac, 47–63 Hz, 1.2 kW [10 amps] (Installation Category II) - standard furnace 230 Vac, 47–63 Hz, 1.2 kW [5 amps] (Installation Category II) - standard furnace 120 Vac, 47–63 Hz, 1.0 kW [8.33 amps] (Installation Category II) - EGA furnace 230 Vac, 47–63 Hz, 1.0 kW [4.16 amps] (Installation Category II) - EGA furnace 1.44 kW max with full power delivered through accessory outlets.
Laboratory Conditions:	Temperature 15–35°C (Note: TGA balance mechanism is sensitive to changes in surrounding room temperature. For best results, room temperature should be regulated to eliminate temperature variations) Relative Humidity 5–80% (non-condensing) Instrument should be located in a dust-free, vibration-free environment [a marble balance table is recommended], away from exposure to direct sunlight and direct air drafts. (Pollution Degree 2 Environment). Maximum Altitude 2000 m (6560 ft)
Laboratory Requirements:	Purge Gas(es) Pressure <sup>(1)(2)</sup> 70–140 kPa gauge (10–20 psig) Cooling Gas (Air) Pressure <sup>(1)</sup> 170–830 kPa gauge (25–120 psig)
<p><sup>(1)</sup> All gases must be dry and free of oil, dirt and water. The Purge Gases are connected to the back of the instrument using 1/8-inch (O.D.) Teflon® tubing and Legris fittings. (Tubing is provided in the TGA accessory kit.) The Cooling Gas is connected to the back of the instrument using ¼ inch (O.D.) Teflon tubing and a Legris fitting. (The fitting at the unit is supplied on the instrument. The ¼-inch tubing and connector at the tank are provided by the customer.) Acceptable purge gases include air, nitrogen, oxygen, argon and helium.</p> <p><sup>(2)</sup> Purge gases are required for the balance and furnace/sample areas. Balance purge gas should always be inert to protect the balance assembly. Mass flow controllers (MFC) are a standard feature of the Q500 and are optional for the Q50. If your instrument does not have an MFC, two external flow meters are required. Purge gas flow rates are 40 mL/min and 60 mL/min to the balance and sample areas respectively for the standard furnace. They are 10 mL/min and 90 mL/min to the balance and sample areas for the EGA furnace.</p>	

## Q600 SDT

Dimensions:	Depth 56 cm (22 in), Width 59.7 cm (23.2 in), Height 48 cm (19 in)
Weight: Weight with Transformer:	32 kg (70 lbs) 40 kg (88 lbs)
Power Requirements:	120 Vac, 47–63 Hz, 1.2 kW [10 amps] (Installation Category II) 230 Vac, 47–63 Hz, 1.2 kW [5 amps] (Installation Category II) 1.44 kW max with full power delivered through accessory outlets.
Laboratory Conditions:	Temperature 15–30 °C Relative Humidity 5–80% (non-condensing) Instrument should be located in a dust-free, vibration-free environment [a marble balance table is recommended], away from exposure to direct sunlight and direct air drafts. (Pollution Degree 2 Environment). Maximum Altitude 2000 m (6560 ft)
Laboratory Requirements:	Purge Gas Pressure <sup>(1)(2)</sup> 70–140 kPa gauge (10–20 psig) Cooling Gas (Air) Pressure <sup>(1)</sup> 170–830 kPa gauge (25–120 psig)
<p><sup>(1)</sup> All gases must be dry and free of oil, dirt and water. The Purge Gases are connected to the back of the instrument using 1/8-inch (O.D.) Teflon® tubing and Legris fittings. (Tubing is provided in the accessory kit.) The Cooling Gas is connected to the back of the instrument using ¼ inch (O.D.) Teflon tubing and a Legris fitting. (The fitting at the unit is supplied on the instrument. The ¼-inch tubing and connector at the tank are provided by the customer.) Acceptable purge gases include air, nitrogen, argon and helium.</p> <p><sup>(2)</sup> Purge gas should always be inert to protect the balance assembly. A mass flow controller (MFC) is a standard feature of the Q600 to regulate the purge gas. Typical purge gas flow rate is 100 mL/min. A secondary purge is available for the introduction of a "reactive" gas at modest concentration in the area of the sample. Typical secondary gas flow rate is 20 mL/min.</p>	

## Q400 TMA

Dimensions:	Depth 55.9 cm (22 in), Width 45.5 cm (18 in), Height with furnace open 64.8 cm (25.5 in), Height with furnace closed 61 cm (24 in)
Weight: Weight with Transformer:	31.4 kg (69 lbs) 39.5 kg (87 lbs)
Power Requirements:	120 Vac, 47–63 Hz, 1.2 kW [10 amps] (Installation Category II) 230 Vac, 47–63 Hz, 1.2 kW [5 amps] (Installation Category II) 1.44 kW max with full power delivered through accessory outlets.
Laboratory Conditions:	Temperature 15–30 °C Relative Humidity 5–80% (non-condensing) Instrument should be located in a dust-free, vibration-free environment [a marble balance table is recommended], away from exposure to direct sunlight and direct air drafts. (Pollution Degree 2 Environment). Maximum Altitude 2000 m (6560 ft)
Laboratory Requirements:	Purge Gas Pressure <sup>(1)(2)</sup> 100–140 kPa gauge (15–20 psig) Cooling Gas (Air) Pressure <sup>(1)</sup> 170–830 kPa (25–120 psig)
<p><sup>(1)</sup> All gases must be dry and free of oil, dirt and water. The Purge Gases are connected to the back of the instrument using 1/8-inch (O.D.) Teflon® tubing and Legris fittings. (Tubing is provided in the accessory kit.) The Cooling Gas is connected to the back of the instrument using ¼ inch (O.D.) Teflon tubing and a Legris fitting. (The fitting at the unit is supplied on the instrument. The ¼-inch tubing and connector at the tank are provided by the customer.) Acceptable purge gases include air, nitrogen, oxygen, argon and helium.</p> <p><sup>(2)</sup> A mass flow controller (MFC) is an optional feature used to regulate the purge gas. Typical purge rates are 100 mL/min. If your instrument does not have an MFC, an external flow meter is required.</p>	

## Q800 DMA

Dimensions:	Depth: 56 cm (22 in.), Width: 46 cm (18 in.), Height: furnace open 71 cm (28 in.), furnace closed 56 cm (22 in.)
Weight: Weight with Transformer:	39.5 kg (87 lbs) 47.7 kg (105 lbs)
Power Requirements:	120 Vac, 47–63 Hz, 600 W [5 amps] (Installation Category II) 230 Vac, 47–63 Hz, 600 W [2.5 amps] (Installation Category II) 1.44 kW max with full power delivered through accessory outlets.
Laboratory Conditions:	Temperature 15–30 °C Relative Humidity 5–80% non-condensing Instrument should be located in a dust-free, vibration-free environment [a marble balance table is recommended], away from exposure to direct sunlight and direct air drafts. (Pollution Degree 2 Environment). Maximum Altitude 2000 m (6560 ft)
Laboratory Requirements:	Air Bearing Gas Pressure <sup>(1)(2)</sup> 410–450 kPa gauge (60–65 psig); flow rate 2 L/min Cooling Gas (Air) Pressure <sup>(1)</sup> 170–830 kPa gauge (25–120 psig)
<p><sup>(1)</sup> All gases must be dry and free of oil, dirt and water. The Cooling Gas is connected to the back of the instrument using ¼ inch (O.D.) Teflon® tubing and a Legris fitting. (The fitting at the unit is supplied on the instrument. The ¼-inch tubing and connector at the tank are provided by the customer.)</p> <p><sup>(2)</sup> TA Instruments' Air Compressor Accessory (ACA) is available for laboratories that do not have a suitable supply of air bearing gas.</p>	

# Requirements for Miscellaneous Thermal Analysis Accessories

## Refrigerated Cooling System (RCS) for use with Q10, Q100 and Q1000 DSC's

See the figure to the right for the correct placement of the RCS unit on the laboratory bench to the left of the QDSC instrument.

Below is a schematic showing you how to connect the gas plumbing lines to the instrument for the use of an RCS.



Placement of RCS and QDSC

Dimensions:	Depth 46 cm (18 in), Width 25 cm (10 in), Height 52 cm (21 in).
Weight:	48 kg (105 lbs)
Power Requirements:	115 Vac, 60 Hz, 1.4 kW 230 Vac, 50 Hz, 1.4 kW
Laboratory Requirements:	Same general environmental requirements as DSC. A base and cooling purge (nitrogen) is required in addition to the standard cell purge. See page 10.

### RCS Gas Plumbing Diagram

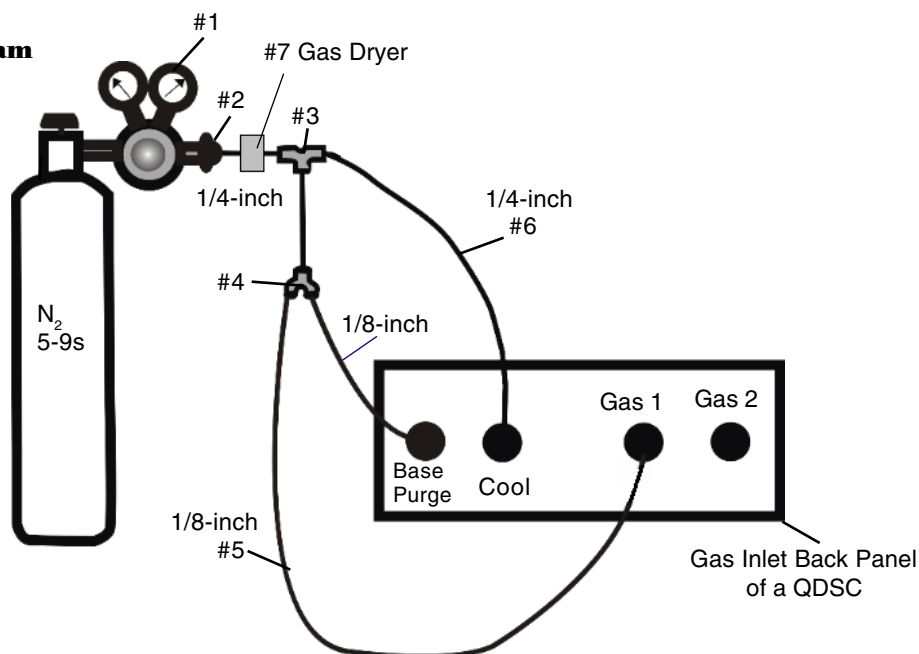



### TA Instruments Accessory Kit Items for use with RCS

Item	Quantity	Description
1	1	Regulator
2	1	Legris 1/4 OD Tube to 1/4 Male NPT
3	1	Legris 1/4 OD Tee x 1/8 OD Tube
4	1	Legris "Y" 1/8 Tube x 1/8 Tube
5	15 ft	Tubing Teflon 1/8-inch OD x .030 W
6	25 ft	Tubing Polypropylene 1/4-inch
7	1	Gas Dryer, PN 200266.001

Notes:

1. Items 1 and 7 are available as parts on the Item Master price list.
2. Items 2 – 6 are located in the DSC Accessory Kit, 970012.901.
3. Use 99.999% pure nitrogen to reduce moisture
4. New or recently serviced and calibrated regulator is recommended.
5. Do not use Tygon tubing due to its high moisture permeability.
6. Make sure that the tubing is cut cleanly and squarely on the ends.
7. Leak check all tubing.
8. Use gas dryer, PN 200266.001, to prevent moisture buildup.

### Liquid Nitrogen Cooling System (LNCS) for use with Q10, Q100, and Q1000 DSC's

See the figure to the right for the correct placement of the LNCS unit on the floor to the left of the QDSC instrument.

On the next page is a schematic showing you how to connect the gas plumbing lines to the instrument for the use of an LNCS.



Placement of LNCS with QDSC

Dimensions:	Width (diameter) 53 cm (21 in), Height 109 cm (43 in). (Unit designed to sit on floor.)
Weight:	52 kg (113 lbs) - empty; 88 kg (193 lbs) - full
Power Requirements:	85–264 Vac, 50/60 Hz, 0.18 kW
Laboratory Requirements:	Same general environmental requirements as DSC. LNCS autofills during usage. Should be connected to a 160 L liquid nitrogen tank with pressure of 150–170 kPa (22–25 psi). A base and cooling purge (nitrogen) is required in addition to the standard cell purge. See page 10 of this document.

## LNCS Gas Plumbing Diagram

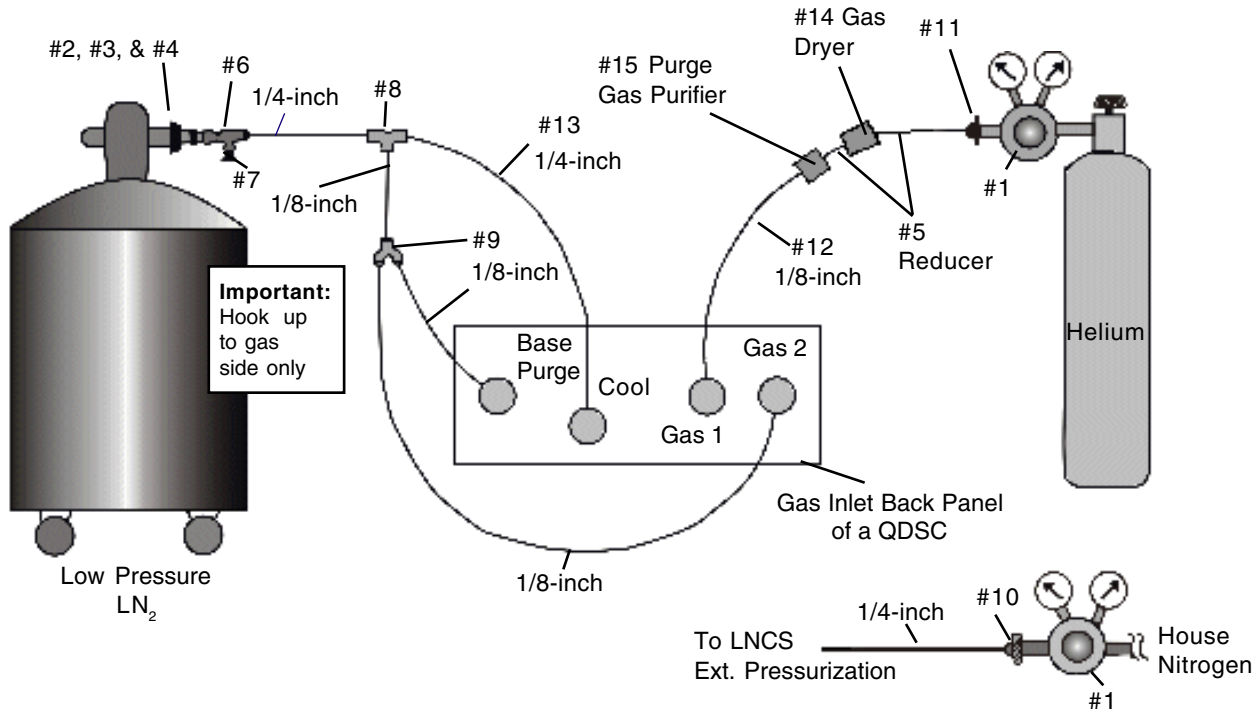

TA Instruments Accessory Kit Items for use with LNCS

Item	Quantity	Description
1	2	Regulator, 0 to 40 PSI out
2	1	92 Nut, CGA-580
3	1	15-3 Nipple CGA-580
4	1	Coupler, Female-Female 1/4 NPT
5	2	Legris Plug-in Reducer 1/8 OD x 1/4 OD
6	1	Legris Male Run Tee 1/4 OD x 1/4 NPT
7	1	Legris Plug 1/4 OD
8	1	Legris Tee 1/4 x 1/8 Tube
9	1	Legris Union "Y" 1/8 Tube to 1/8 Tube
10	1	Legris 1/4 OD Tube to 1/4 Male NPT
11	1	Legris 1/8 OD Tube to 1/4 Male NPT
12	15 ft	Tubing Teflon 1/8-inch OD x .030 W
13	25 ft	Tubing Polypropylene 1/4-inch
14	1	Gas Dryer, PN 200266.001
15	1	Purge Gas Purifier, PN 970425.901

### Notes:

- Items 1, 14, and 15 are available as parts on the Item Master Price List
- Items 2 – 5 are in the LNCS Accessory Kit (970398.901)
- Items 6 – 13 are in the DSC Accessory Kit (970012.901)
- Use new or recently serviced and calibrated regulators.
- Do not use Tygon tubing due to its high moisture permeability.
- Make sure that the tubing is cut cleanly and squarely on the ends.
- Leak check all tubing.
- Use **99.999%** pure **Helium** to reduce moisture buildup in the cell.
- Use the gas dryer, PN 200266.001, to pre-dry and indicate unsatisfactory moisture levels.
- Use the purge gas purifier, PN 970425.901, to achieve a dewpoint of  $-180^{\circ}\text{C}$

## Finned Air Cooling System (FACS) for use with Q10, Q100, and Q1000 DSC's

This section provides the laboratory requirements for the FACS and a schematic showing you how to connect the gas plumbing lines to the instrument for the use of an FACS.

Laboratory Requirements:	Same general environmental requirements as DSC. Cooling Gas (Air) Pressure for use with Finned Air Cooling System 70–830 kPa gauge (25-120 psig). See page 10 of this document.
--------------------------	---------------------------------------------------------------------------------------------------------------------------------------------------------------------------------------

### FACS Gas Plumbing Diagram

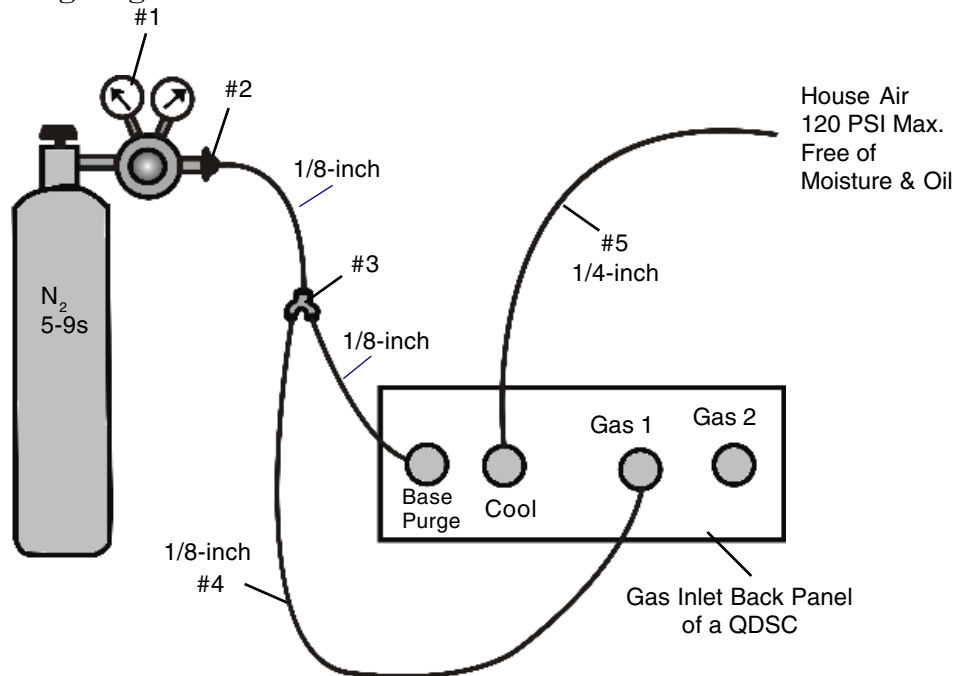

### TA Instruments Accessory Kit Items for use with FACS

Item	Quantity	Description
1	1	Regulator
2	1	Legris 1/8 OD Tube to 1/4 Male NPT
3	1	Legris "Y" 1/8 Tube x 1/8 Tube
4	15 ft	Tubing Teflon 1/8-inch OD x .030 W
5	25 ft	Tubing Polypropylene 1/4-inch

#### Notes:

- Item 1 is available as a part on the Item Master price list.
- Items 2 – 5 are located in the DSC Accessory Kit, 970012.901.
- FACS uses cool gas constantly; therefore clean house air should be used. A filter is recommended.
- Use standard grade nitrogen.
- New or recently serviced and calibrated regulator is recommended.
- Make sure that the tubing is cut cleanly and squarely on the ends.
- Leak check all tubing.

### **Air Compressor Accessory (ACA) for use with DMA Q800**

Dimensions:	Depth 38 cm (15 in), Width 38 cm (15 in), Height 23 cm (9 in)
Weight:	10 kg (22 lbs)
Power Requirements:	120 Vac, 50/60 Hz, 0.3 kW
Laboratory Requirements:	Same general environmental requirements as DMA. Should not be located in an enclosed area. Heat build-up occurs if air does not flow freely around the unit. Requires the use of a moisture filter regulator <u>with</u> autodrain, which is included with the DMA.

### **Gas Cooling Accessory (GCA) for use with DMA Q800**

Dimensions:	Width (diameter): Dewar 46 cm (18 in), Feet 79 cm (31 in); Height: 107 cm (42 in)
Weight:	46 kg (101 lbs.) - empty; 87 kg (191 lbs) - full
Power Requirements:	120 Vac at 0.9 kW, 47–63 Hz
Laboratory Requirements:	Same general environmental requirements as DMA. GCA is refilled by connecting to a 160L liquid nitrogen tank with pressure of 450–170 kPa (20–25 psi).

### **Mechanical Cooling Accessory (MCA) for use with TMA Q400**

Dimensions:	Depth 38 cm (15 in), Width 46 cm (18 in), Height 53 cm (21 in)
Weight:	50 kg (110 lbs)
Power Requirements:	115 Vac, 60 Hz, 1 kW 230 Vac, 50 Hz, 1.2 kW
Laboratory Requirements:	Same general environmental requirements as TMA. No additional purge gas requirements.

### **Photocalorimeter Accessory (PCA) for use with DSC Q1000/Q100**

Dimensions:	Depth 44 cm (17 in.) Width 28 cm (11 in), Height 15 cm (6 in)
Weight:	9.4 kg (21 lbs)
Power Requirements:	90–132/180–246 Vac, 47–63 Hz; autorange selectable
Laboratory Requirements:	Same general environmental requirements as Q1000 and Q100.

### **Liquid Nitrogen Cooling Accessory (LNCA) for use with DEA 2970**

Dimensions:	Width (diameter) 46 cm (18 in), Height 128 cm (50 in) (Unit designed to sit on floor)
Weight:	30 kg (65 lbs) - empty; 70 kg (154 lbs) - full
Power Requirements:	120 Vac, 50/60 Hz, 0.48 kW
Laboratory Requirements:	Same general environmental requirements as DEA. No additional purge gas requirements. LNCA is refilled by connecting to a 160L liquid nitrogen tank with pressure of 150–170 kPa (22–25 psi).

## Requirements for the Rheology Instruments

The following section summarizes laboratory requirements by instrument. Each section contains all of the requirements for that particular instrument. Therefore, some items will be redundant, if you have purchased a multi-module system.

### AR 2000 Rheometers

Dimensions:	Depth 32 cm (12.5 in), Width 30 cm (11.75 in), Height 67 cm (26.5 in) - AR 2000 Depth 45 cm (17.75 in), Width 18.5 cm (7.25 in), Height 37.5 cm (14.75 in) - AR 2000 Electronics unit
Weight:	28.7 kg (62.2 lbs.) 17.3 (38.1 lbs.) additional for controller (Electronics unit) 6.8 kg (15.4 lbs.) additional for ETC accessory
Power Requirements:	110–230 Vac, 45/65 Hz, 1000 W (Installation Category II)
Laboratory Conditions:	Temperature 15–35 °C Relative Humidity $\leq$ 80% non-condensing Instrument should be located in a dust-free, vibration-free environment, away from exposure to direct sunlight and direct air drafts. (Pollution Degree 2 Environment) Maximum Altitude 2000 m (6560 ft)
Laboratory Requirements:	Air Bearing Gas Pressure (air or nitrogen) must be clean, dry, oil-free compressed air at 50–100 psi. The dew point should be -20°C or better. Flow rate should be 25 L/min.

### Smart Swap™ Requirements

Peltier Plate & Peltier Concentric Cylinder	Water (required for Peltier) 0.5 L/min flow if supplied from house water line; recirculating water bath supplied with rheometer is alternative. TA Peltier cooling kit supplied with rheometer is for temporary use only.
Environmental Test Chamber (ETC)	Purge gas flow rate should be 10 L/min at 20 psi. Optional cooling liquid nitrogen at 20 to 30 psi.
Starch Pasting Cell	Water at minimum flow rate through cell of 0.2 L/min. Maximum temperature 15 °C. Air flow rate should be 1 L/min at 20 psi.
Upper Heated Plate	Circulating fluid minimum flow rate 0.2 L/min. Air flow rate should be 1 L/min at 20 psi.

## AR 550/1000 Rheometers

Dimensions:	Depth 25 cm (10 in), Width 22 cm (9 in), Height 60 cm (23.5 in) - AR 500 Depth 25 cm (10 in), Width 22 cm (9 in), Height 60 cm (23.5 in) - AR 1000 Depth 43 cm (17 in), Width 18.5 cm (7.25 in), Height 37 cm (14.5 in) - AR 500/1000 Electronics unit
Weight:	22 kg (48.5 lbs.) 21 kg (47 lbs) additional for controller (Electronics unit) 6.8 kg (15.4 lbs.) additional for ETC accessory 17 kg (38 lbs.) additional for an ETM accessory
Power Requirements:	110–230 Vac, 45/65 Hz, 1000 W (Installation Category II)
Laboratory Conditions:	Temperature 15–35 °C Relative Humidity ≤80% non-condensing Instrument should be located in a dust-free, vibration-free environment, away from exposure to direct sunlight and direct air drafts. (Pollution Degree 2 Environment) Maximum Altitude 2000 m (6560 ft)
Laboratory Requirements:	Air Bearing Gas Pressure (air or nitrogen) must be clean, dry, oil-free compressed air at 50–100 psi. The dew point should be -20°C or better. Flow rate should be 25 L/min. Water (required for Peltier) 0.5 L/min flow if supplied from house water line; recirculating water bath supplied with rheometer is alternative. TA Peltier cooling kit supplied with rheometer is for temporary use only.
Temperature System Requirements:	Water (required for Peltier) 0.5 L/min flow if supplied from house water line; recirculating water bath supplied with rheometer is alternative. TA Peltier cooling kit supplied with rheometer is for temporary use only.
Fluid Jacket Concentric Cylinder/CSAII	For full system integration a Julabo FS-18 or F-30, fitted with TA Instruments firmware, is required.
Environmental Test Chamber	Purge gas flow rate should be 10 L/min at 20 psi. Optional cooling liquid nitrogen at 20 to 30 psi.

## QCR and CSA II Rheometers

The AR 550 Rheometer is the base unit used to build the QCR and CSA II (Asphalt Rheometer). Therefore, the specifications for those rheometers are essentially those shown for the AR 550 above.

## Starch Pasting Rheometer\*

\* The AR 1000 Rheometer is the base unit used to build the Starch Pasting Rheometer (SPR). Therefore, the specifications for those rheometers are essentially those shown for the AR 1000.

Starch Pasting Cell	Water at minimum flow rate through cell of 0.2 L/min. Maximum temperature 15 °C. Air flow rate should be 1 L/min at 20 psi.
---------------------	-----------------------------------------------------------------------------------------------------------------------------

## ARES Rheometer

Dimensions:	Depth 53 cm (21 in), Width 66 cm (26 in), Height 91 cm (36 in)
Weight:	136 kg (300 lbs.)
Power Requirements:	180–264 Vac, 50/60 Hz, 20 Amps (Installation Category II) Twist Lock Receptacle (NEMA L6-20R) and Plug
Laboratory Conditions:	Temperature 15–35 °C Relative Humidity $\leq 80\%$ non-condensing Instrument should be located in a dust-free, vibration-free environment, away from exposure to direct sunlight and air drafts. (Pollution Degree 2 Environment) Maximum Altitude 2000 m (6560 ft)
Laboratory Requirements:	Air supplied by Air Dryer (See page 27 of this document). Other options available. The suggested minimum work table size is 87 cm x 165 cm (34 in x 65 in). Access of 61 cm (24 in) behind the table is recommended for service and maintenance.

## ARES Placement

The ARES base system consists of the Test Station and Host Computer.

Select a location for the ARES with adequate floor space and a solid rigid laboratory bench that is level, has a minimum depth of 76 cm (30 in), and with a length of approximately 213 cm (84 in). Please refer to the layout shown in the figure below for component placement.

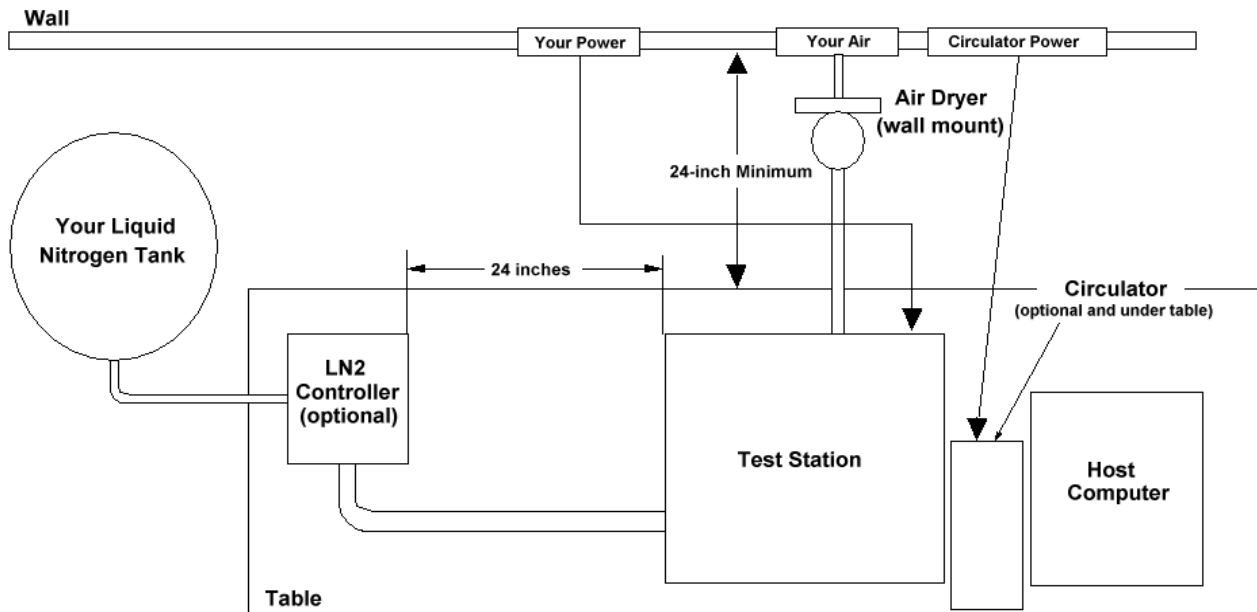

Top View of ARES Component Layout



Refer to the tables for the ARES and its various components for the physical, electrical and pneumatic specifications of each item.



**CAUTION:** The test station must be located on a rigid and reasonably level surface to prevent erroneous sample results from vibrations due to table or floor movements, outside noise or people hitting the table or the instrument.

### RSA III Solids Rheometer/DMA

Dimensions:	Depth 53 cm (21 in), Width 66 cm (26 in), Height 91 cm (36 in)
Weight:	136 kg (300 lbs.)
Power Requirements:	180–264 Vac, 50/60 Hz, 20 Amps (Installation Category II) Twist Lock Receptacle (NEMA L6-20R) and Plug
Laboratory Conditions:	Temperature 15–35 °C Relative Humidity ≤80% non-condensing Instrument should be located in a dust-free, vibration-free environment, away from exposure to direct sunlight and air drafts. (Pollution Degree 2 Environment) Maximum Altitude 2000 m (6560 ft)
Laboratory Requirements:	Air supplied by Air Dryer ( See page 27 of this document). Other options available. The suggested minimum work table size is 87 cm x 165 cm (34 in x 65 in). Access of 61 cm (24 in) behind the table is recommended for service and maintenance.

### RSA III Placement

The RSA III base system consists of the Test Station and Host Computer.

Select a location for the RSA III with adequate floor space and a solid rigid laboratory bench that is level, has a minimum depth of 76 cm (30 in), and with a length of approximately 213 cm (84 in). Please refer to the layout shown in the figure below for component placement.

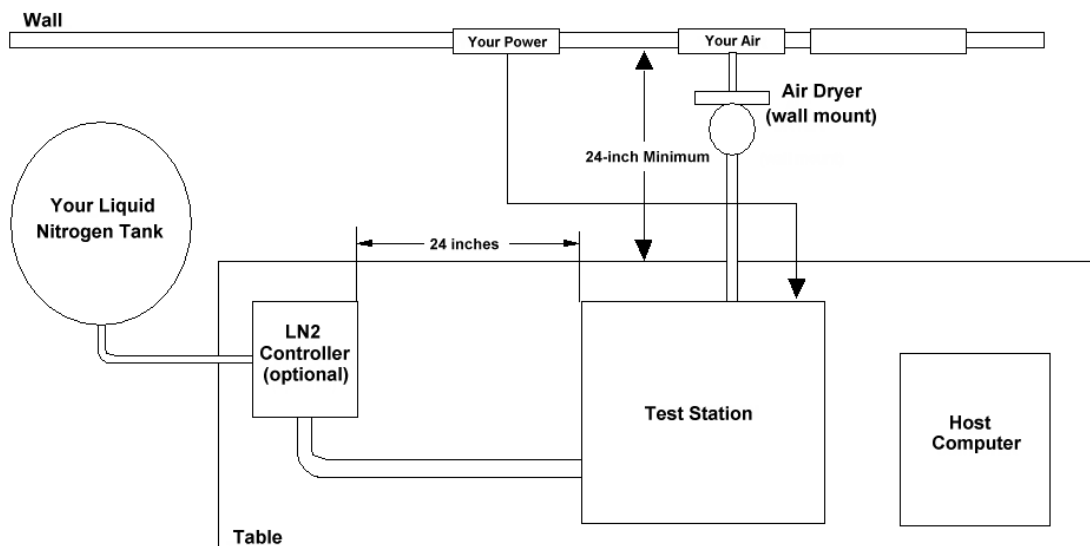

RSA III Placement Layout

# Requirements for Miscellaneous Rheology Accessories

## Liquid Nitrogen Dewar

(Used with the AR Rheometers ETC and ETM accessories for subambient operation.)

Dimensions:	Width 46 cm (18 in), Height 128 cm (50 in) (Unit designed to sit on floor.)
Weight:	48 kg (106 lbs.) - Empty 96 kg (211 lbs.) - Full
Power Requirements:	None
Laboratory Requirements:	Same general environmental requirements as rheometer. Dewar is refilled by connecting to a 160 liter nitrogen tank with a pressure of 150–170 kPa gauge (22–25 psig). The diameter of the standard 160 L external LN <sub>2</sub> tank is approximately 51 cm (20 in). Allowance should be made for the tank to stand at the LN <sub>2</sub> Controller (left) end of the table.

## Liquid Nitrogen Controller

(Used with ARES and RSA III Rheometers. Optional for Forced Convection Oven.)

Dimensions:	Width 28 cm (11 in), Height 56 cm (22 in), Depth 24 cm (9.5 in)
Weight:	17.3 kg (38 lbs.)
Power Requirements:	Supplied by test station
Laboratory Requirements:	Same general environmental requirements as rheometer. Liquid nitrogen supply tank at 20 to 30 psi, 12 L/hr Because of its design, the LN <sub>2</sub> Controller must be located to the left and slightly behind the ARES or RSA III.  If optional liquid nitrogen (LN <sub>2</sub> ) is to be used, provide a 160 Liter (or larger) tank or an in-house supply with a ½-inch, 45° flared fitting, isolated by a shutoff valve. LN <sub>2</sub> pressure in excess of 30 psi may cause damage to the LN <sub>2</sub> Controller. Most in-house supplies of the LN <sub>2</sub> tends to contain a certain volume of gaseous nitrogen (N <sub>2</sub> ), which occurs as a result of the natural boil off from the liquid. This gas must be first vented off the supply line (near the LN <sub>2</sub> Controller) before delivery is sent to the LN <sub>2</sub> Controller. Failure to observe this caution may cause the LN <sub>2</sub> Controller to malfunction frequently.

## Air Dryer

(Used with ARES and RSA III Rheometers)

Dimensions:	Width 40.6 cm (16 in), Height 30.5 cm (12 in), Depth 12.7 cm (5 in)
Weight:	3.2 kg (7 lbs.)
Power Requirements:	None
Laboratory Requirements:	<p>Same general environmental requirements as rheometer. Inlet air: 100 psig; 5.5 scfm (fluids), 9.0 scfm (with oven);</p> <p>The air dryer <b>MUST</b> be mounted upright on the wall within 183 to 244 cm (6 to 8 feet) of the air source. The center holes of its two mounting brackets are 22.2 cm (8.75 in) apart. The air dryer is about 25.4 cm (12 in) high and weighs about 3.2 kg (7 lbs.).</p> <p>The customer should provide a means to connect to a 3/8" NPT male connector on the inlet hose of the air dryer (provided by TA Instruments). The customer should provide a gauge to monitor the 100 psi (7.0 bars) source of clean dry air into the air dryer. The air supply from the air dryer must be regulated to provide 80 psi (5.5 bars) into the test station. The inlet pressure and flow rate will vary depending on type of motor and environmental system.</p> <p>Air Dryers are designed to remove moisture from the air. They are <u>not</u> designed to remove water from the air. If you have excessive moisture levels, which results in the immediate condensation into water, the membrane type air dryer may get over saturated and cause damage. Your maintenance personnel should install an external 'Water Trap', before feeding the air into the Air Dryer. Inlet air should be at Relative Humidity of 70% or less, at RT with particle size of 5 microns or less.</p>
<p><b>NOTE: Only air is to be connected into the main pneumatic inlet. DO NOT connect nitrogen gas into the main pneumatic inlet. Nitrogen gas will damage the motor assembly.</b></p> <p> <b>WARNING: The air into the instrument must meet the above requirements or damage to a major component within the instrument may occur. Such damage is NOT covered by Warranty written or implied.</b></p>	

## Gas Chiller

(Used with in conjunction with Forced Convection Oven for ARES and RSA III.)

**NOTE:** The air dryer accompanying the Gas Chiller is a dedicated dryer that can only be used for the air supplied to the chiller. It cannot be used to dry any other air supplies.

Dimensions:	Width 74 cm (29 in), Height 127 cm (50 in), Depth 51 cm (20 in)
Weight:	68 kg (150 lbs.)
Power Requirements:	197 to 253 Vac @ 60 Hz; 180 to 220 Vac @ 50 Hz 15 Amp with receptacle and plug; Buck-boost transformer available for 50Hz sites over 220 Vac
Laboratory Requirements:	Same general environmental requirements as rheometer. Fitting for 1/4-inch ID hose Air/N <sub>2</sub> supply 80 psi @ 5.5 scfm Inlet air temperature no higher than 77°F (25°C). Gas Chiller is designed to be on the left side or rear of the ARES, on the floor.

## Circulator (Julabo FS-18)

(Used with ARES Rheometers. Used with Bath and/or Peltier. Must be placed on floor.)

Dimensions:	Width 30.5 cm (12 in), Height 64 cm (25 in), Depth 43 cm (17 in)
Weight:	34 kg (74 lbs.)
Power Requirements:	115 Vac @ 60 Hz; 230 Vac @ 50 Hz 15 Amp
Laboratory Requirements:	Same general environmental requirements as rheometer.

# TA Instruments Offices

For information on our latest products and more, see our web site at: [www.tainstruments.com](http://www.tainstruments.com).

TA Instruments—Waters LLC  
109 Lukens Drive  
New Castle, DE 19720  
Telephone: 1-302-427-4000 or  
1-302-427-4040  
Fax: 1-302-427-4001  
Email: [INFO@tainstruments.com](mailto:INFO@tainstruments.com)

## HELPLINE—U.S.A.

For assistance with thermal analysis applications, please call the Thermal Analysis Help Desk at 1-302-427-4070.

## SERVICE—U.S.A.

For instrument service and repairs, please call 1-302-427-4050.

## BELGIUM/LUXEMBOURG

TA Instruments a Division of Waters N.V.  
Raketstraat 60 Rue de la Fusée  
1130 Brussel / Bruxelles  
Belgium  
Phone: 32/2 706 00 80  
Fax: 32/2 706 00 81

## DENMARK

Advanced Technology  
Ormeslevvej 29, Ormeslev  
DK-4241 Vemmelev, Denmark  
Phone: 45 58 38 38 00  
Fax: 45 58 38 38 03

## EUROPE

TA Instruments Ltd  
Block D, The Fleming Centre  
Fleming Way, Roya Manor  
Crawley, West Sussex, RH10 9NB  
England  
Phone: 44/01293 658900  
Fax: 44/01293 658901

## FINLAND

Waters Finland Oy  
Kuparitie 1  
Fin-00440 Helsinki  
Finland  
Phone: 358 (0) 9 5064140  
Fax: 358 (0) 9 50641411

## FRANCE

TA Instruments Division de Waters SA  
1-3, Rue Jacques Monod  
78280 Guyancourt  
France  
Phone: 33/1 30 48 94 60  
Fax: 33/1 30 48 94 51

## GERMANY

TA Instruments Germany  
Max Planck Strasse 11  
63755 ALZENAU  
Germany  
Phone: 49/6023 96470  
Fax: 49/6023 964777

## IRELAND

AGB Scientific  
Dublin Industrial Estate,  
Glasnevin, Dublin 11,  
Ireland  
Phone: 353 1 8822 222  
Fax: 353 1 8822 333

## ITALY

TA Instruments - Div. Di Waters S.p.A.  
Via Achille Grandi, 27  
20090 Vimodrone (Milano),  
Italy  
Phone: 39/02 2742 11  
Fax: 39/02 250 1827

## JAPAN

TA Instruments Japan  
No. 5 Koike Bldg.  
1-3-12 Kitashinagawa  
Shinagawa-Ku, Tokyo 140-0001  
Japan  
Phone: 813 5479 8418 (Sales & Application)  
Fax: 813 5479 7488 (Sales & Application)  
Phone: 813 3450 0981 (For Service & Accounting)  
Fax: 813 3450 1322 (For Service & Accounting)

## NORWAY

Hvamstubben 17  
N-2013 Skjetten  
Norway  
Phone: 47 63846055  
Fax: 47 63846051

**THE NETHERLANDS**

TA Instruments  
A Division of Waters Chromatography bv  
Postbus 379 / Florijnstraat 19  
4870 AJ Etten-Leur  
The Netherlands  
Phone: 31/76 508 72 70  
Fax: 31/76 508 72 80

**PORTUGAL**

Elnor  
R.D. Frei Jeronimo de Brito e Melo N° 835  
Leca do Balio — Apt 1019  
4470 Maia Codex, Portugal  
Phone: 351 22 905 0400  
Fax: 351 22 905 0499

**SPAIN**

Waters Cromatografia S.A.  
Division TA Instruments  
Parc Tecnologic del Valles  
Ronda de Can Fatjo, 7-a  
08290-Cerdanyola del Valles  
Spain  
Phone: 34 93 600 93 00  
Fax: 34 93 600 93 60

**SWEDEN**

TA Instruments Division of Waters Sweden  
PO Box 485  
19124 Sollentuna  
Sweden  
Phone: 46 (0) 8 555 11 500  
Fax: 46 (0) 8 555 11 520