

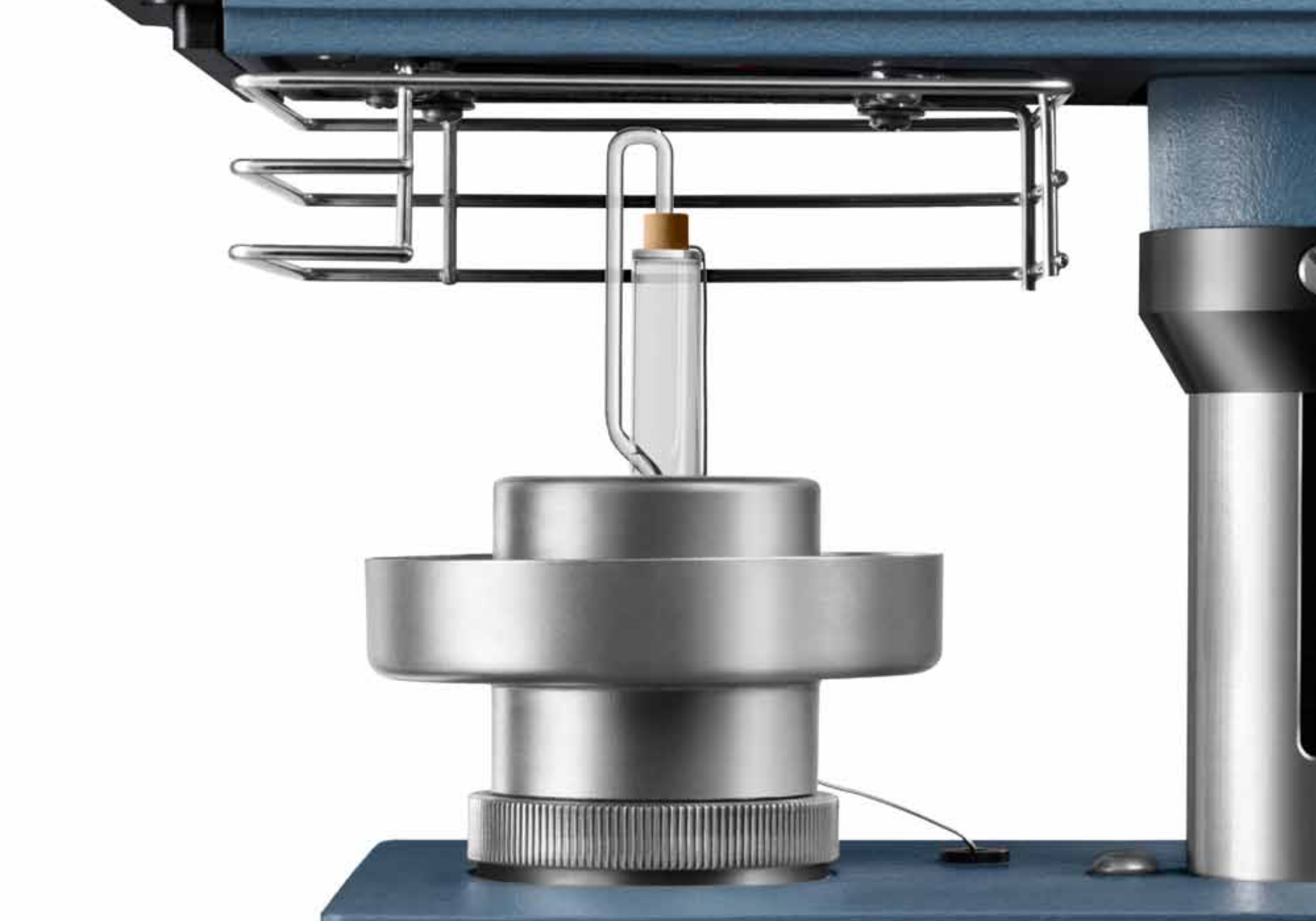

TA Instruments  
**THERMAL ANALYSIS**



A close-up photograph of a mechanical device. On the left, a blue-painted metal structure is visible, featuring a black cylindrical component and a silver-colored vertical rod. To the right, a large, dark grey or black curved surface, possibly a sensor or probe, is shown in profile. The background is a plain, light color.

THERMOMECHANICAL **ANALYSIS**

---

*Sensitive Measurement, Unmatched Versatility*

---

TMA Q400EM/Q400  
**SPECIFICATIONS**



The Q400EM is the industry's leading research-grade thermomechanical analyzer with unmatched flexibility in operating modes, test probes, and available signals. The Enhanced Mode (EM) allows for additional transient (stress/strain), dynamic and Modulated TMA™ experiments that provide for more complete viscoelastic materials characterization plus a way to resolve overlapping thermal events (MTMA). The Q400 delivers the same basic performance and reliability as the Q400EM but without the latter's advanced features. It is ideal for research, quality control, and teaching applications.

	Q400EM	Q400
Temperature Range (max)	-150 to 1 000°C	-150 to 1 000°C
Temperature Precision	± 1°C	± 1°C
Furnace Cool Down Time (air cooling)	<10 min from 600°C to 50°C	<10 min from 600°C to 50°C
Maximum Sample Size - solid	26 mm (L) x 10 mm (D)	26 mm (L) x 10 mm (D)
Maximum Sample Size - film/fiber		
Static Operation	26 mm (L) x 1.0 mm (T) x 4.7 mm (W)	26 mm (L) x 1.0 mm (T) x 4.7 mm (W)
Dynamic Operation	26 mm (L) x .35 mm (T) x 4.7 mm (W)	—
Measurement Precision	± 0.1%	± 0.1%
Sensitivity	15 nm	15 nm
Displacement Resolution	<0.5 nm	<0.5 nm
Dynamic Baseline Drift	<1 µm (-100 to 500°C)	<1 µm (-100 to 500°C)
Force Range	0.001 to 2 N	0.001 to 2 N
Force Resolution	0.001 N	0.001 N
Frequency Range	0.01 to 2 Hz	—
Mass Flow Control	Included	Included
Atmosphere (static or controlled flow)	Inert, Oxidizing, or Reactive Gases	Inert, Oxidizing, or Reactive Gases
<b>Operational Modes</b>		
Standard	Included	Included
Stress/Strain	Included	—
Creep	Included	—
Stress Relaxation	Included	—
Dynamic TMA (DTMA)	Included	—
Modulated TMA™ (MTMA™)	Included	—

# Q400 TECHNOLOGY

A thermomechanical analyzer measures sample dimensional changes under conditions of controlled temperature, time, force, and atmosphere. Our engineering experience in design and integration of critical furnace, temperature, dimension measurement, and atmosphere-control components meld with powerful, flexible software to optimize the numerous tests available which the Q Series™ TMA can perform.

## Furnace

The Q400 vertical furnace is designed for high performance, reliability and long life in a wide variety of applications. Customized electronics provide the temperature control and response required for superior baselines, enhanced sensitivity and Modulated TMA™ operation. Software control of the furnace movement ensures operational convenience and simplified sample loading/unloading. The Inconel® 718 Dewar atop the furnace allows continuous operation in cyclic heating/cooling studies using the new optional mechanical cooling accessory (MCA 70).

## Sample Stage

The easily accessible stage simplifies installation of the available probes (see Modes of Deformation), sample mounting, and thermocouple placement. An integral digital mass flow controller meters the flow of purge gas to the sample area. Precise and responsive temperature control and the well-regulated purge gas result in optimized performance in the standard and MTMA modes of operation. The design benefits also include flexibility in operation and ease of use.

## Linear Variable Differential Transducer

The heart of the Q400 TMA sample measurement system is the precision, moveable-core, linear variable differential transducer (LVDT), which generates an accurate output signal that is directly proportional to a sample dimension change. Its precise and reliable response over a wide temperature range (-150 to 1 000°C) ensures reproducible TMA results. Its location below the furnace protects it from temperature effects and ensures stable baseline performance.

## Force Motor

A non-contact motor provides a controlled, friction-free, calibrated force to the sample via a probe or fixture. The force is digitally programmed from 0.001 to 1N, and can be increased manually to 2 N by addition of weights. The motor precisely generates the static, ramped or oscillatory dynamic forces necessary for quality measurements in all deformation modes. Ten individual frequencies are available for optimizing data quality in dynamic TMA experiments in compression, 3-point bending, or tension modes of deformation.

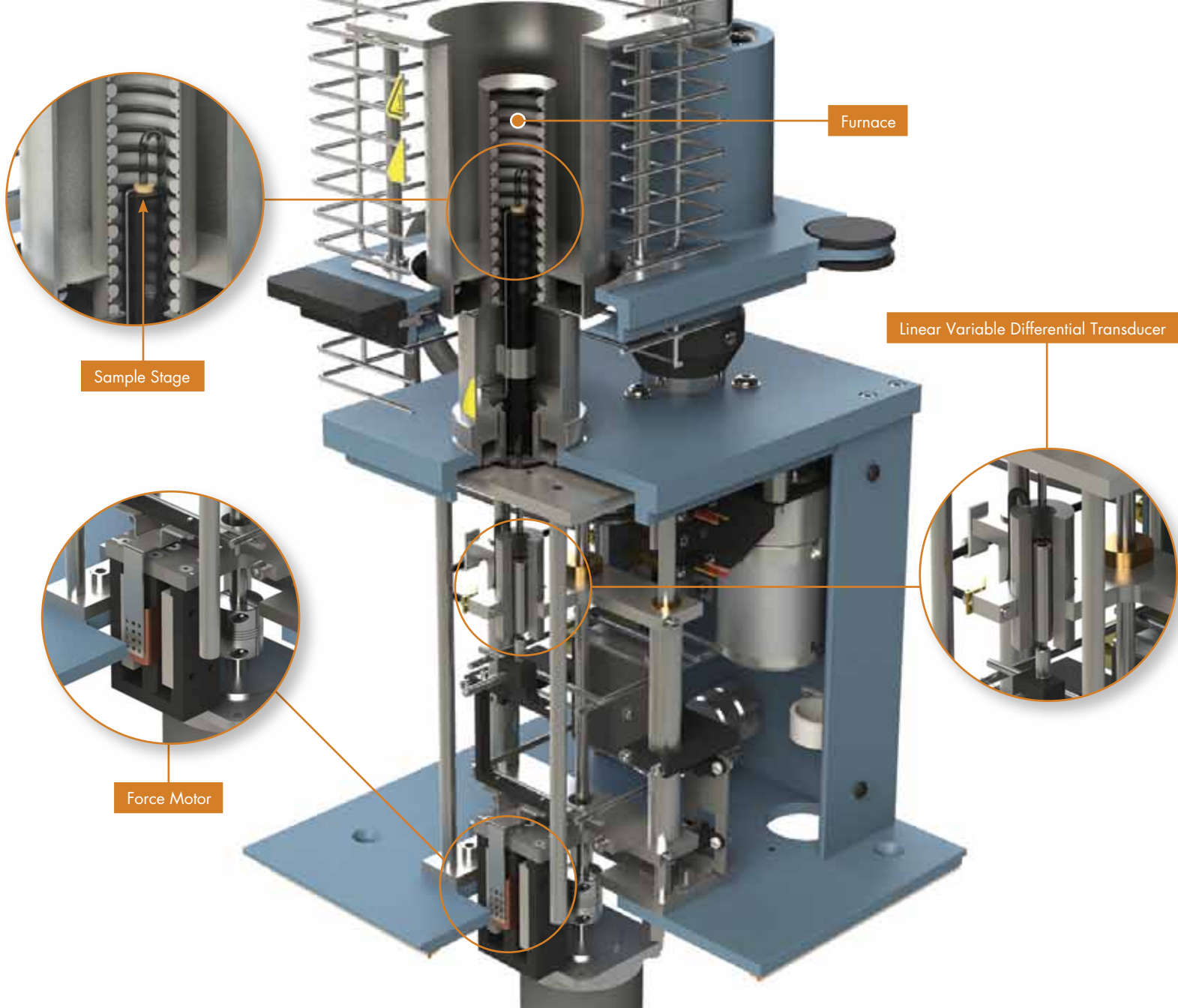

# MODES OF DEFORMATION

The Q400 offers all the major TMA deformation modes necessary to characterize a wide range of materials such as solids, foams, films, and fibers. These include expansion, penetration, compression, tension, and 3-point bending.

## Expansion

Expansion measurements determine a material's coefficient of thermal expansion (CTE), glass transition temperature ( $T_g$ ), and compression modulus. A flat-tipped standard expansion probe is placed on the sample (a small static force may be applied), and the sample is subjected to a temperature program. Probe movement records sample expansion or contraction. This mode is used with most solid samples. The larger surface area of the macro-expansion probe facilitates analysis of soft or irregular samples, powders, and films.

## Penetration

Penetration measurements use an extended tip probe to focus the drive force on a small area of the sample surface. This provides precise measurement of glass transition ( $T_g$ ), softening, and melting behavior. It is valuable for characterizing coatings without their removal from a substrate. The probe operates like the expansion probe, but under a larger applied stress. The hemispherical probe is an alternate penetration probe for softening point measurements in solids.

## Tension

Tensile studies of the stress/strain properties of films and fibers are performed using a film/fiber probe assembly. An alignment fixture permits secure and reproducible sample positioning in the clamps. Application of a fixed force is used to generate stress/strain and modulus information. Additional measurements include shrinkage force,  $T_g$ , softening temperatures, cure, and cross-link density. Dynamic tests (e.g. DTMA, MTMA™) in tension can be performed to determine viscoelastic parameters (e.g.,  $E'$ ,  $E''$ ,  $\tan \delta$ ), and to separate overlapping transitions.

## Compression

In this mode, the sample is subjected to either a static, linear ramp, or dynamic oscillatory force, while under a defined temperature program and atmosphere. Sample displacement (strain) is recorded by either expansion/penetration experiments and used to measure intrinsic material properties, or by dynamic tests and used to determine viscoelastic parameters, detect thermal events, and separate overlapping transitions (MTMA).

## 3-Point Bending

In this bending deformation (also known as flexure), the sample is supported at both ends on a two-point, quartz anvil atop the stage. A fixed static force is applied vertically to the sample at its center, via a wedge-shaped, quartz probe. This mode is considered to represent "pure" deformation, since clamping effects are eliminated. It is primarily used to determine bending properties of stiff materials (e.g., composites), and for distortion temperature measurements. Dynamic measurements are also available with the Q400EM, where a special, low-friction, metallic anvil replaces the quartz version.

## Dilatometer Probe Kit

A specialty dilatometer probe kit is also available for the Q400 and Q400EM. This kit includes a special dilatometer probe, small quartz vial to enclose the sample and a filling medium. Whereas TMA generally measures the linear Coefficient of Thermal Expansion (CTE), the dilatometer kit is designed to determine the Coefficient of Volume Expansion, or CVE, of a material.

The expansion, macro-expansion, and penetration probes are supplied with the Q400. These probes, plus the flexure probe, and the low-friction bending fixture, are included with the Q400EM module. Data analysis programs relevant to each of the measurements described are provided in our Advantage™ software.





# TMA THEORY/MODES OF OPERATION

TMA measures material deformation changes under controlled conditions of force, atmosphere, time and temperature. Force can be applied in compression, flexure, or tensile modes of deformation using specially designed probes described in pages 102-103. TMA measures intrinsic material properties (e.g., expansion coefficient, glass transition, Young's modulus), plus processing/product performance parameters (e.g., softening points). These measurements have wide applicability, and can be performed by either the Q400 or the Q400EM. The Q400 and Q400EM operating modes permit multiple material property measurements. The Q400 features the Standard mode, while the Q400EM additionally offers Stress/Strain, Creep, Stress Relaxation, Dynamic TMA, and Modulated™ TMA modes as described below.

## Standard Mode (Q400/Q400EM)

Temperature Ramp: Force is held constant and displacement is monitored under a linear temperature ramp to provide intrinsic property measurements. Isostrain (shrinkage force): Strain is held constant and the force required to maintain the strain is monitored under a temperature ramp. This permits assessment of shrinkage forces in materials such as films/fibers. Force Ramp: Force is ramped and resulting strain is measured at constant temperature to generate force/displacement plots and modulus assessment.

## Stress/Strain Mode (Q400EM)

Stress or strain is ramped, and the resulting strain or stress is measured at constant temperature. Using customer-entered sample geometry factors, the data provides both stress/strain plots and related modulus information. In addition, calculated modulus can be displayed as a function of stress, strain, temperature, or time.

### Standard Mode

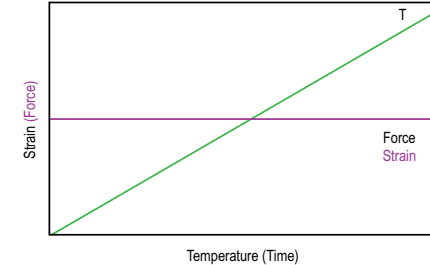

### Standard Mode

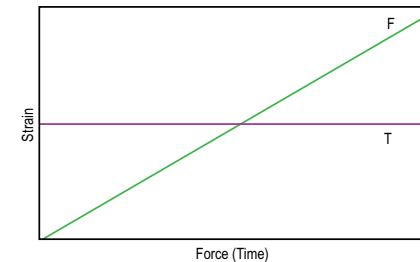

### Stress/Strain Mode (Q400EM)

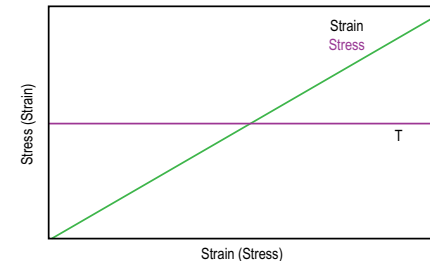

## Creep and Stress Relaxation (Q400EM)

TMA can also measure viscoelastic properties using transient (creep or stress relaxation) tests. These require the Q400EM module. In a creep experiment, input stress is held constant, and resulting strain is monitored as a function of time. In a stress relaxation experiment, input strain is held constant, and stress decay is measured as a function of time. The data can also be displayed in units of compliance (creep mode) and stress relaxation modulus (stress relaxation mode).

## Modulated TMA™ (MTMA™; Q400EM)

In Modulated TMA (MTMA), the sample experiences the combined effects of a linear temperature ramp and a sinusoidal temperature of selected amplitude and period. The output signals (after Fourier transformation of the raw data) are total displacement and the change in thermal expansion coefficient. Both can be resolved into their reversing and non-reversing component signals. The reversing signal contains events attributable to dimension changes and is useful in detecting related events (e.g.,  $T_g$ ). The non-reversing signal contains events that relate to time-dependent kinetic processes (e.g., stress relaxation). This technique is unique to the Q400EM.

## Dynamic TMA Mode (Q400EM)

In Dynamic TMA (DTMA), a sinusoidal force and linear temperature ramp are applied to the sample (Figure A), and the resulting sinusoidal strain, and sine wave phase difference ( $\delta$ ) are measured (Figure B). From this data, storage modulus ( $E'$ ), loss modulus ( $E''$ ), and  $\tan \delta$  ( $E''/E'$ ) are calculated as functions of temperature, time, or stress (Figure C). This technique can be useful in the analysis of thin polymer films.

## Creep and Stress Relaxation (Q400EM)

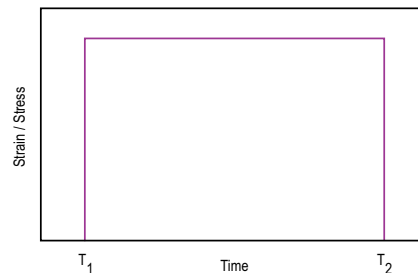

## Dynamic TMA Mode (Q400EM)

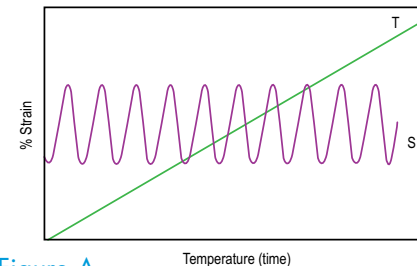

Figure A

## Modulated TMA (MTMA; Q400EM)

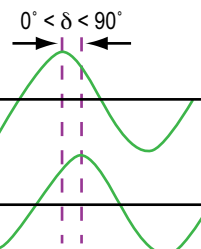
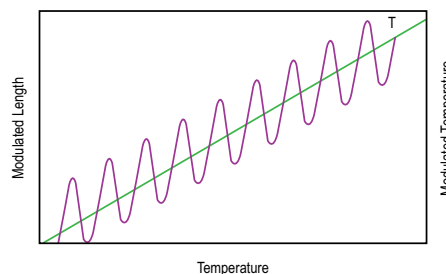

Figure B Viscoelastic Behavior

Figure C

## MECHANICAL COOLING ACCESSORY (MCA70)

The MCA70 is a high performance accessory for the Q400 and Q400EM Thermomechanical Analyzer that permits controlled cooling within the temperature range of 400 to  $-70^{\circ}\text{C}$ . The MCA 70 is ideal for use in cyclic heating/cooling experiments that are increasingly being used by manufacturers to test materials under conditions of actual use and verify their performance.



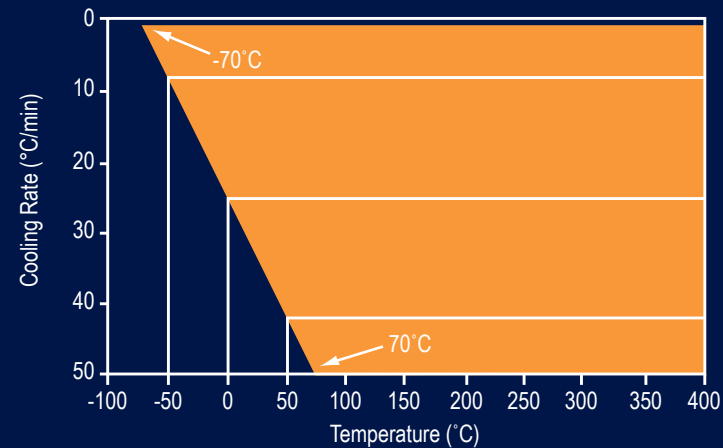

The figure above/below details the operating envelope of the MCA70. Controlled rates are detailed in the table below:

MCA70 Controlled Cooling Rates, from 400°C (upper limit)\*

Controlled Rate	To Lower Temperature
50°C/min	70°C
20°C/min	-15°C
10°C/min	-40°C
5°C/min	-55°C
2°C/min	-65°C

\*Performance may vary slightly, depending on laboratory conditions

# APPLICATIONS

## Intrinsic and Product Property Measurements

This figure shows expansion and penetration probe measurements of the Tg and the softening point of a synthetic rubber using a temperature ramp at constant applied force. The large CTE changes in the expansion plot indicate the transition temperatures. In penetration, the transitions are detected by the sharp deflection of the probe into the sample.

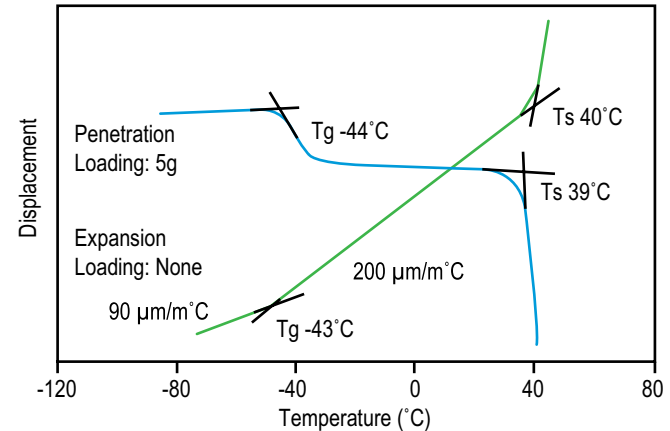

## Accurate Coefficient of Thermal Expansion Measurements

This example demonstrates the use of the expansion probe to accurately measure small CTE changes in an aluminum sample over a 200°C temperature range. Advantage™ software permits analysis of the curve slope using a variety of methods to compute the CTE at a selected temperature, or over a range.

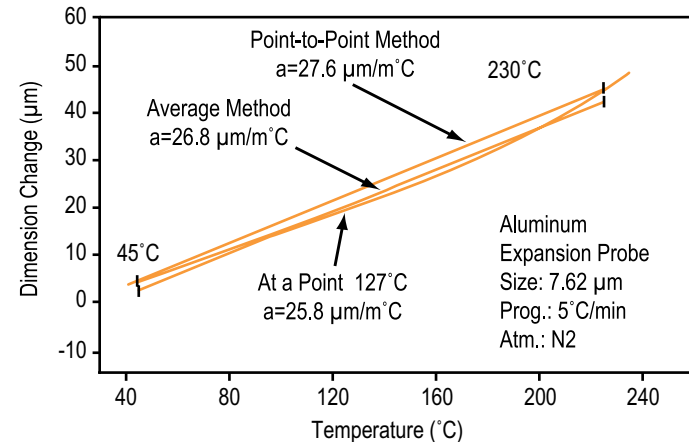

## Material Performance and Selection

The figure to the right is an example of a 3-point bending mode (flexure probe) experiment on a polyvinyl chloride (PVC) sample using the ASTM International Test Method E2092 to determine the distortion temperature or “deflection temperature under load” (DTUL). This test specifies the temperature at which a sample of defined dimensions produces a certain deflection under a given force. It has long been used for predicting material performance.

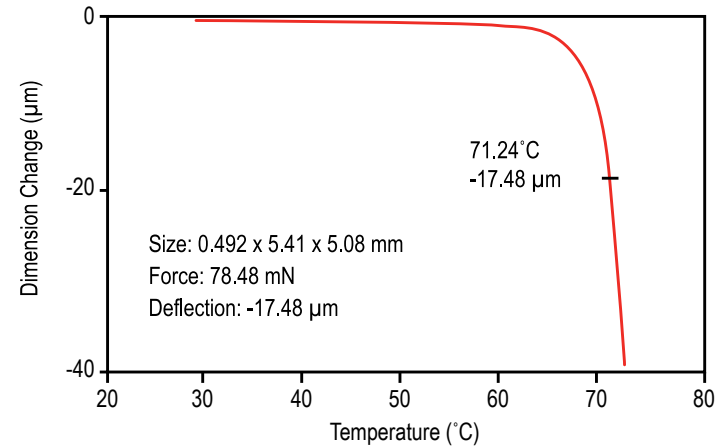

## Multilayer Film Analysis

This figure shows a compression mode analysis, using a penetration probe, of a double layer PE/PET film sample supported on a metal substrate. The sample temperature was ramped from ambient to 275 $^{\circ}\text{C}$  at 5 $^{\circ}\text{C}/\text{min}$ . The plot shows probe penetrations of the PE layer (93.2  $\mu\text{m}$ ) at 103 $^{\circ}\text{C}$ , and the PET layer (14.8  $\mu\text{m}$ ) at 258 $^{\circ}\text{C}$ , respectively.

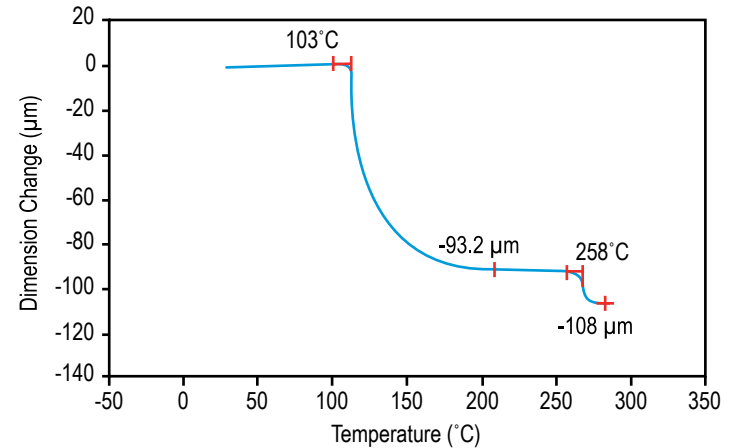

# APPLICATIONS

## Shrinkage Force Testing

This figure illustrates a classic shrinkage force (isostrain) experiment in the tensile mode on a food wrapping film. The film was strained to 20% at room temperature for 5 minutes, cooled to -50°C and held for 5 more minutes, then heated at 5°C/min to 75°C. The plot shows the force variation (shrinkage force) required to maintain a set strain in the film. This test simulates film use from the freezer to the microwave.

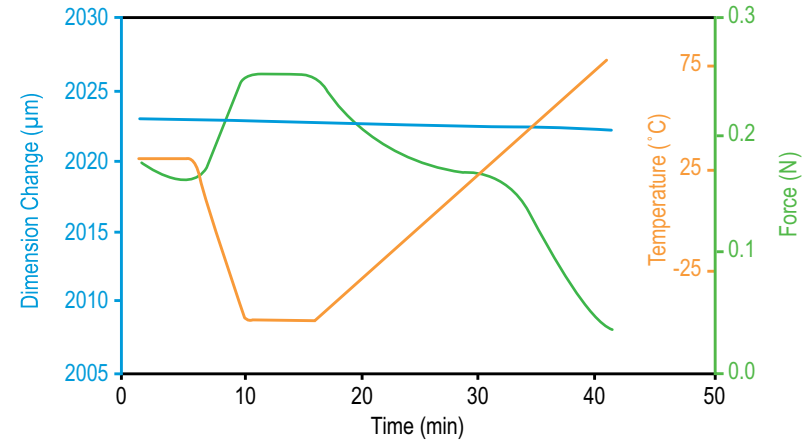

## Film Tensile Testing

The figure to the right displays a strain ramp experiment, at a constant temperature, on a polymeric film in tension. The plot shows an extensive region where stress and strain are linearly related, and over which a tensile modulus can be determined. Quantitative modulus data can also be plotted as a function of stress, strain, time, or temperature. The results show the ability of the Q400EM to function as a mini tensile tester for films and fibers.

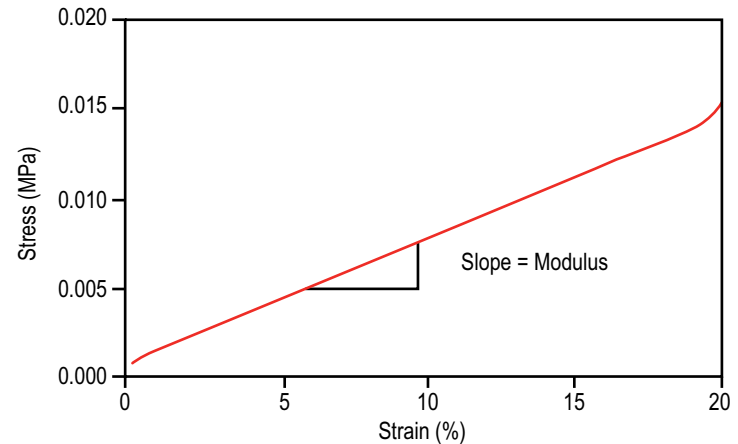



## Fiber Stress/Strain Measurements

Stress/strain measurements are widely used to assess and compare materials. The figure shows the different regions of stress/strain behavior in a 25  $\mu\text{m}$  polyamide fiber in tension, subjected to a force ramp at a constant temperature. The fiber undergoes instantaneous deformation, retardation, linear stress/strain response, and yield elongation. Other parameters (e.g., yield stress, Young's modulus) can be determined.

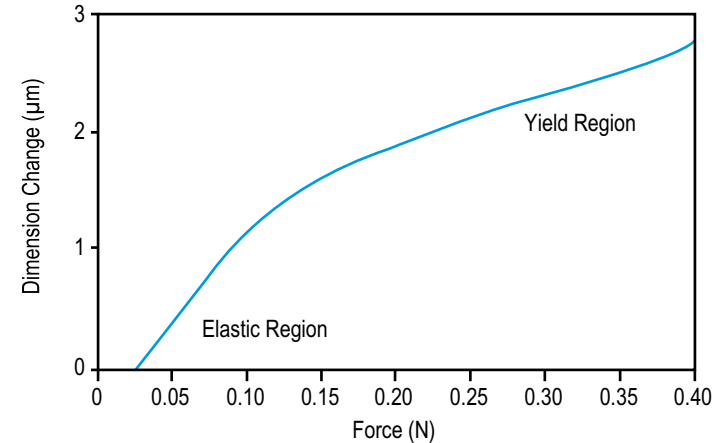

## Thermal Stress Analysis of Fibers

This figure displays a tensile mode experiment, using a temperature ramp at a constant strain (1%), to perform a stress analysis on a polyolefin fiber, as received, and after cold drawing. The plot shows the forces needed to maintain the set strain as a function of temperature. The data has been correlated with key fiber industry processing parameters, such as shrink force, draw temperature, draw ratio, elongation at break, and knot strength.

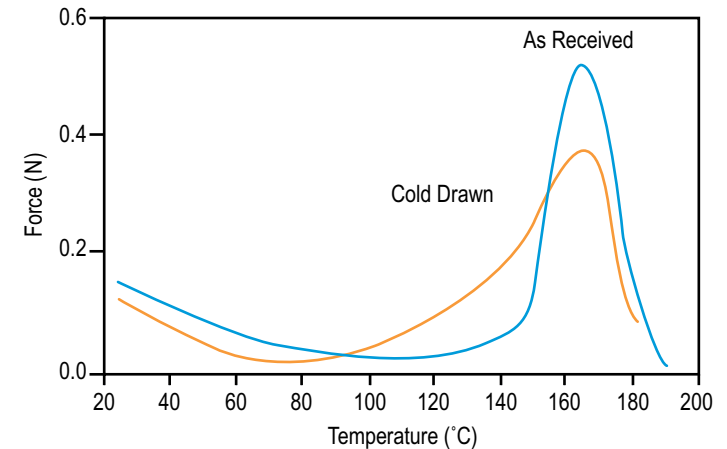

# APPLICATIONS

## Creep Analysis

Creep tests are valuable in materials selection for applications where stress changes are anticipated. This example illustrates an ambient temperature creep study on a polyethylene film in tension. It reveals the instantaneous deformation, retardation, and linear regions of strain response to the set stress, plus its recovery with time, at zero stress. The data can also be plotted as compliance, and recoverable compliance, versus time.

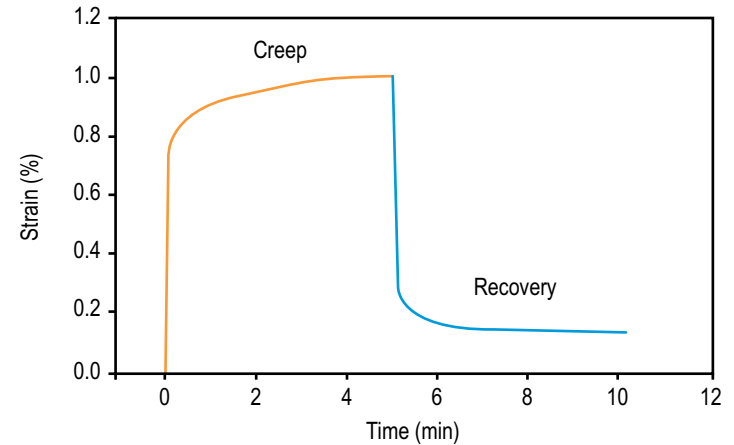

## Stress Relaxation Analysis

This figure shows a stress relaxation test in tension on the same polyolefin film used for the creep study in the previous example. A known strain is applied to the film, and maintained, while its change in stress is monitored. The plot shows a typical decay in the stress relaxation modulus. Such tests also help engineers design materials for end uses where changes in deformation can be expected.

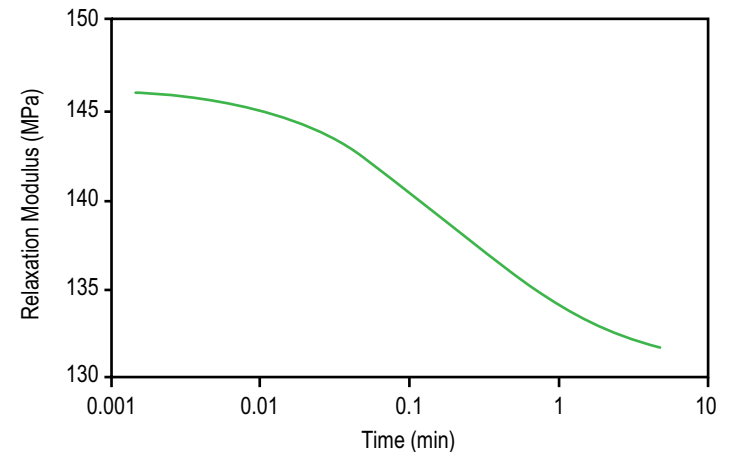

## Viscoelastic Property Determination - Dynamic TMA

This figure illustrates a dynamic test in which a semi-crystalline polyethylene terephthalate (PET) film in tension is subjected to a fixed sinusoidal force during a linear temperature ramp. The resulting strain and phase data are used to calculate the material's viscoelastic properties (e.g.,  $E'$ ,  $E''$ , and  $\tan \delta$ ). The plotted data shows dramatic modulus changes as the film is heated through its glass transition temperature.

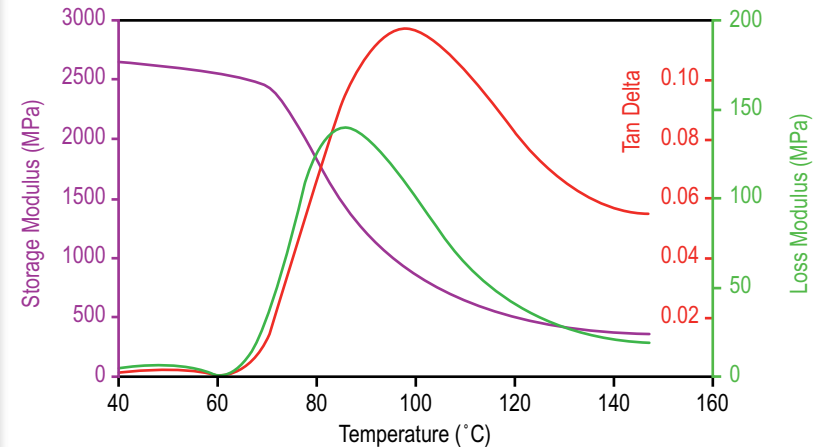

## Separating Overlapping Transitions - Modulated TMA™

The figure to the right shows a MTMA™ study to determine the  $T_g$  of a printed circuit board (PCB). The signals plotted are the total dimension change, plus its reversing and non-reversing components. The total signal is identical to that from standard TMA, but does not uniquely define the  $T_g$ . The component signals, however, clearly separate the actual  $T_g$  from the stress relaxation event induced by non-optimum processing of the PCB.

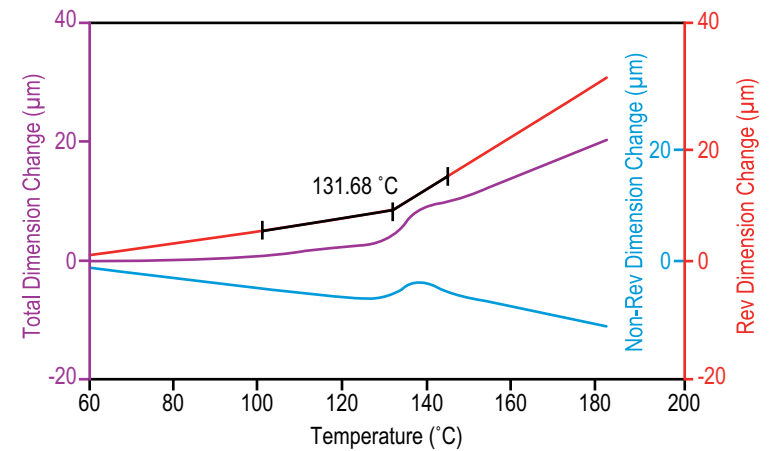



[tainstruments.com](http://tainstruments.com)