



TA Instruments Installation Requirements for Rheology Systems

Notice

Thank you for ordering a rheology system from TA Instruments. To ensure that installation of your system goes as smoothly as possible and has you ready to start evaluating your sample materials as quickly as possible, we are providing the attached installation information. It includes details regarding laboratory space, power, and auxiliary requirements, as well as configuration requirements for the controller (computer). Please review this information carefully and take any appropriate actions prior to the installation date. To avoid unnecessary delays, and/or additional charges, please ensure that the requirements specified in this document are met before your TA Instruments Service Representative arrives. Contact your local TA Instruments Representative if you have any questions.



To arrange for installation of your system, contact our U.S. Service Department (302-427-4050) or your local TA Instruments Service Representative.

Important: TA Instruments Manual Supplement

Please refer to the *TA Manual Supplement* to access the following important information supplemental to this document:

- TA Instruments Trademarks
- TA Instruments Patents
- Other Trademarks
- TA Instruments End-User License Agreement
- TA Instruments Offices

Table of Contents

Notice	1
Important: TA Instruments Manual Supplement	2
Requirements for the Controller (Computer)	4
Free Disk Space Required	7
Other Hardware Considerations	7
Obtaining Hardcopy System Verification For Windows	7
Other Software Considerations	8
System Configurations	8
ARES-G2 and RSA-G2	8
DHR Series and AR Series	8
Requirements for the Rheology Instruments	9
DHR Series Rheometers	9
DHR-3 / DHR-2 Placement	10
DHR-1 Placement	11
AR-G2/AR 2000ex/AR 1500ex Rheometers	12
AR-G2 Placement	13
AR 2000ex, and AR1500ex Placement	14
Smart Swap™ Requirements for DHR Series and AR Series Rheometers	15
Upper Heated Plate Requirements	15
Gas Cooling Accessory (GCA) for Use with Electrically Heated Plates	16
Circulator (Julabo FP35-HE)	16
Liquid Nitrogen Dewar	16
ARES-G2 Rheometer / RSA-G2 DMA	17
ARES-G2 / RSA-G2 Placement	18
Miscellaneous Rheology Accessories	20
Liquid Nitrogen Controller	20
Air Dryer	21
Gas Chiller	22
Circulator (Julabo FP35-MC)	22
Additional Circulators	23
ThermoCube Peltier Cooling Circulator Model 10-300	23
TA Instruments Offices	24

Requirements for the Controller (Computer)

A working rheology system consists of one or more measurement instruments (for example, a DHR Series Rheometer) and a computer configured with appropriate TA Instruments software (this latter combination is subsequently referred to as a controller). As a customer, you have two alternatives for configuring a controller. You can either purchase a computer and have it configured by a TA Instruments Service representative, or you can purchase a suitable computer on your own and configure it at your site. In either case, the general requirements which follow are the same.



In situations where you are supplying the computer, it is assumed that you have reviewed these requirements and suitably prepared the controller prior to the scheduled system installation by the TA Instruments Service Representative. In fact, you will be required to provide hardcopy verification of your system setup using the instructions on page 7 before an installation visit will be scheduled.

Before installing the TA Instruments software, you should ensure that the computer system meets the following specifications:



For Rheology Advantage, disable dual core processor capability (if applicable to your system components).

Table 1 Computer Requirements (TRIOS [applicable to all rheometers] and Rheology Advantage [applicable to only AR-G2, AR2000ex, and AR1500ex])

Description	Requirement
Operating System ¹	Supported Operating Systems: 32 and 64-bit versions of Windows XP Professional, Vista Business and Ultimate, and Windows 7 Ultimate, Enterprise & Professional ²
Processor	Intel® Core™ 2 Duo (2.93 GHz with 3 MB L2 cache) or better
Memory	≥ 4 GB RAM
Hard Drive	≥ 80 GB free on hard drive
CD-ROM or DVD	≥ 48X CD-ROM or DVD
Screen Resolution	1280 x 1024 (1920 x 1080 recommended) with ≥24-bit colors
Graphic Memory	128 MB for Windows Vista or Windows 7
Screen (LCD) Size	19" or greater (24" wide screen recommended)

1. Install Microsoft Operating System Service Pack, Internet Explorer and/or Direct X (if required). If you don't have the required versions of these packages, they can be obtained through the Microsoft web site (at www.microsoft.com/downloads) or by using the Microsoft Windows Update mechanism (accessed through the Start menu or by accessing <http://update.microsoft.com>).
2. Home version of Windows 7, XP, and/or Vista is not acceptable. Home version is missing certain functionality that is needed for optimized analyzer performance and efficiency.



The Microsoft components .NET Framework and Visual C++ are automatically installed as part of TRIOS and Advantage V4.7 or higher. The specific versions of these components vary depending on the software package installed. These components support the latest software development tools used in TRIOS/ Advantage, as a result, software installation may take longer than in previous versions.

Table 2 Optional Requirements for DHR Series and AR Series Instruments

Description	Required
USB II Port	Required for DHR, AR-G2, and AR2000ex with ETC and Peltier Camera Viewer options, Small Angle Light-Scattering (SALS) Accessory, and Automatic Asphalt Calibration kit.
Network Card	Ethernet 10Base T/100 Base TX
Additional Ethernet Card	Only necessary if connecting instrument directly and need access to Corporate LAN.
Ethernet Cabling	10/100BaseTX Ethernet hub/switch. Must be EIA-568B Category 5+ UTP
Client-Server Protocol	DHCP
Additional Networking Components for Windows XP	Networking Services, as well as file and printer sharing for Microsoft Network and Internet Protocol (TCP/IP)
Image Capture (Camera Option)	DirectX 9.0 or higher
Support for Custom Reporting	Rheology Advantage Navigator software only: Microsoft Word 97 or higher
Second Monitor	Recommended for SALS Accessory image viewing

Table 3 Additional Requirements for ARES-G2 and RSA-G2

Description	Required
Network Card	Ethernet 10Base T/100 Base TX
Ethernet Cabling	10/100BaseTX Ethernet hub/switch. Must be EIA-568B Category 5+ UTP
Additional Networking Components for Windows 2000/XP	Networking Services, as well as file and printer sharing for Microsoft Network and Internet Protocol (TCP/IP)
USB II Port	Required for Camera Accessory.

Table 4 Additional Requirements for Instrument Control Software

Description	Required
User Log-in Capability	While multiple users may still use the “Fast User Switching” Windows XP function when running Windows XP or Vista, only one user at a time may use the TA Instruments Instrument Control software. This limit, which is applicable to most programs, is a result of hardware resources that are used by each of these programs.

Free Disk Space Required

To help you determine which components to install, we have provided the following table containing the approximate amount of free disk space required for installation of the TA Instruments software.



This amount is above that required for the operating system, plus the other software products supplied on the installation CD-ROM. In addition, an extra 15 MB of free disk space is required during the install process (for temporary install files).

Software	Instrument Control and Data Analysis	Full Installation
TRIOS	384 MB (Rheology only)	592 MB (includes Thermal + Rheology)
Advantage	344 MB (Rheology only)	1058 MB (includes Thermal + Rheology)

Other Hardware Considerations

- The computer should be a new computer that is not already attached to other analytical instruments.
- Before the TA Instruments Service Representative will schedule a visit to install new instruments, please obtain a hard copy of the Windows[®] system summary as instructed below to verify that your system is adequate. Please fax this verification sheet along with your company identification and phone number to TA Instruments Service at 302-427-4054.

Obtaining Hardcopy System Verification For Windows

- 1 Select **Programs > Accessories > System Tools > System Information** from the **Start** menu.
- 2 Verify **System Summary** is highlighted.



If you print out this summary from this step you will receive all system information (more than 50 pages). Follow the remaining steps to copy and print only summary information.

- 3 Select **Edit > Select All**, then select **Edit > Copy**.
- 4 Open Notepad or another word processing program.
- 5 Select **Edit > Paste** then **File > Print**.

Other Software Considerations

- Peripherals (e.g., printer) must be from the known Windows XP/Vista compatible list. (See Microsoft's website at <http://www.microsoft.com/hwtest> for the most current list.)
- TA Instruments is not responsible for resolving issues associated with connections to your corporate network. [See further information in the next section.]
- TA Instruments is not responsible for resolving hardware/software conflicts created by the addition of third party hardware or software to the computer.

System Configurations

ARES-G2 and RSA-G2

The ARES-G2 and RSA-G2 communicate with the controller via TCP/IP. If you want to connect the instrument and controller to your in-house network, additional considerations will apply. Your MIS/IT department should configure the Ethernet card in the controller for communication with your in-house network.

DHR Series and AR Series

Rheometers communicate with the controller via TCP/IP. If you want to connect a DHR Series or AR Series Rheometer and controller to your in-house network, additional considerations will apply. Your MIS/IT department should configure the Ethernet card in the controller for communication with your in-house network.

Requirements for the Rheology Instruments

The following sections summarize laboratory requirements by instrument. Each section contains all of the requirements for that particular instrument. Therefore, some items will be redundant, if you have purchased a multi-instrument system.

DHR Series Rheometers

Main Instrument	
Width	32 cm (12.5 in)
Height	76 cm (30 in)
Depth	42 cm (16.5 in)
Weight	32 kg (70.5 lbs)
Electronics Control Box	
Width	26 cm (10 in)
Height	48 cm (19 in)
Depth	44 cm (17 in)
Weight	14 kg (31 lbs)
Power Requirements	110–230 Vac, 50/60 Hz, 1.4 kW (Installation Category II)
Laboratory Conditions	<p>Temperature 5–40°C</p> <p>80% Maximum Relative Humidity for temperatures up to 31°C, decreasing linearly to 50% relative humidity at 40°C.</p> <p>Instrument should be located in a dust-free, vibration-free environment, away from exposure to direct sunlight and direct air drafts. (Pollution Degree 2 Environment)</p> <p>Maximum Altitude 2000 m (6560 ft)</p> <p>The following factors should be minimized, if possible:</p> <ul style="list-style-type: none"> Vibrations from the lab bench Vibrations from the floor Air Flow directed from air-condition duct work Doors being opened and closed Vibration from water flow to peltier/ sample plate Room temperature variations Magnetic impulses Variations in main air supply pressure
Laboratory Requirements	Air Bearing Gas Pressure (air or nitrogen) must be clean, dry, oil-free compressed air at 345–690 kPa gauge (50–100 psig). The dew point should be –20°C or better. Flow rate should be 25 L/min. A 1/4 NPT female connection must be provided for the DHR main air supply.
Optional Motor Cooling	Water 0.5 L/min (30.5 in ³ /min) flow if supplied from house water line; recirculating water bath supplied with rheometer is an alternative. Water temperature must be above ambient.

DHR-3 / DHR-2 Placement

The DHR Series base system consists of the electronics box and instrument.

Select a location for the DHR with adequate floor space. A solid rigid laboratory bench that is level and has a minimum depth of 76 cm (30 in), and with a width of approximately 152 cm (60 in) is recommended for the computer and electronics control box. A sturdy table, marble is preferred, with a minimum depth of 76 cm (30 in), and with a width of approximately 61 cm (24 in) is recommended. Please refer to the layout shown in the figure below for component placement.

DHR-3 or DHR-2 Placement Layout

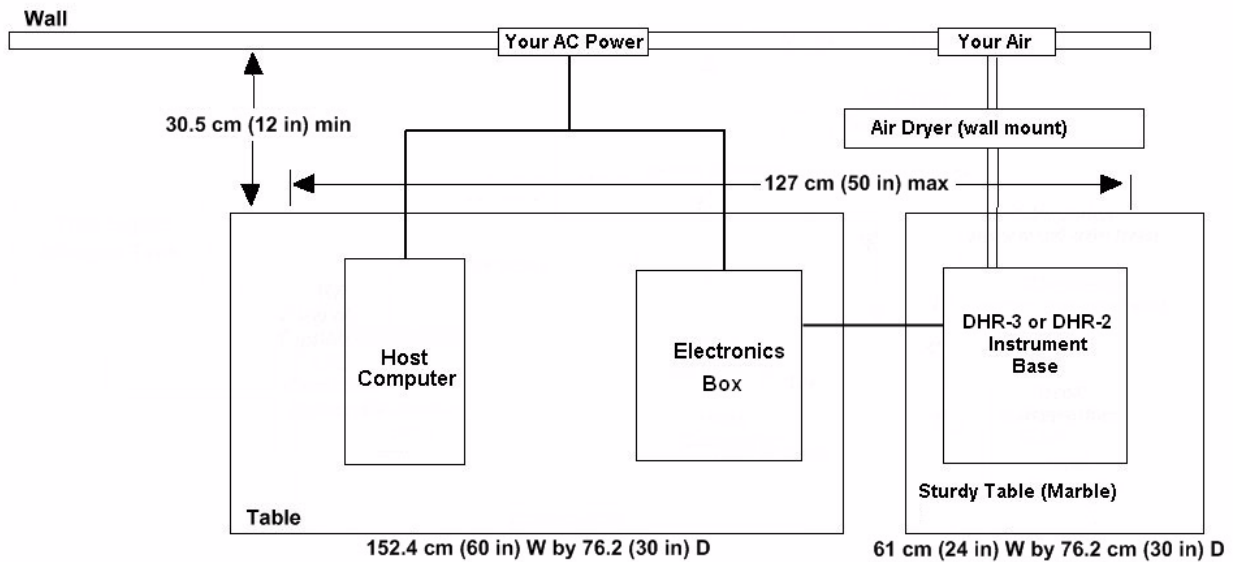

DHR-1 Placement

The DHR Series base system consists of the electronics box and instrument.

Select a location for the DHR-1 with adequate floor space and a solid rigid laboratory bench that is level has a minimum depth of 76 cm (30 in), and with a width of approximately 182 cm (72 in). Please refer to the layout shown in the figure below for component placement.

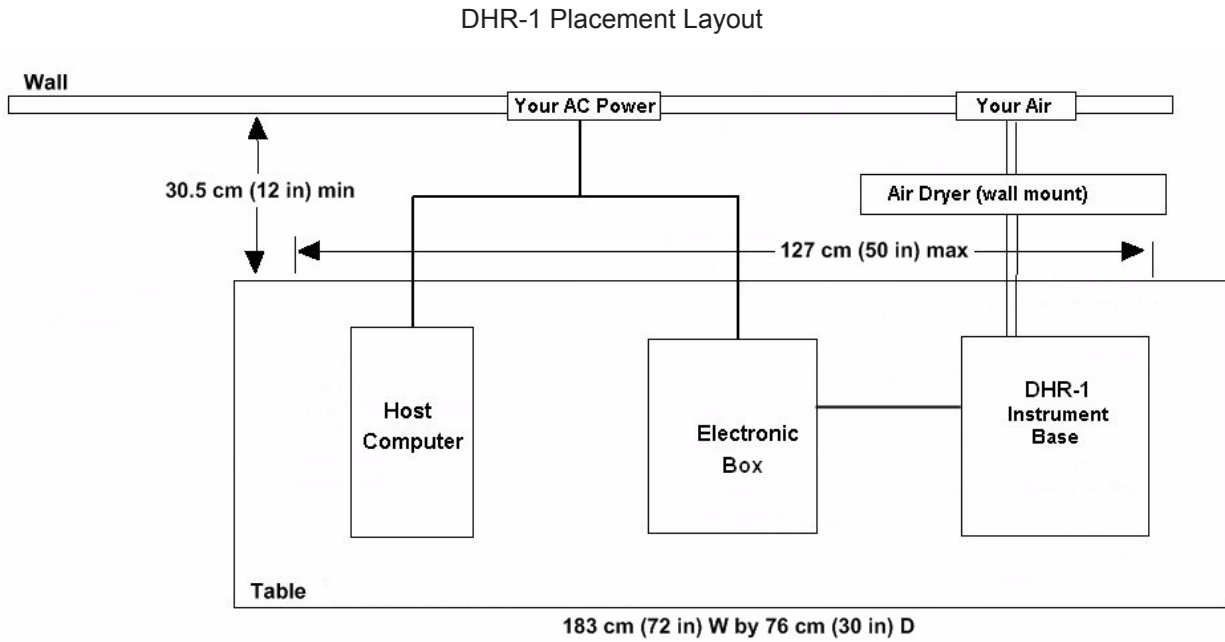

AR-G2/AR 2000ex/AR 1500ex Rheometers

Dimensions	Rheometer Depth 32 cm (12.5 in), Width 30 cm (11.75 in), Height 67 cm (26.5 in) Electronics Depth 45 cm (17.75 in), Width 18.5 cm (7.25 in), Height 37.5 cm (14.75 in)
Weight	29 kg (63.8 lbs) 17.3 kg (38.1 lbs) additional for controller (Electronics unit) 7.35 kg (16.2 lbs) additional for ETC accessory
Power Requirements	110–230 Vac, 50/60 Hz, 1.4 kW (Installation Category II)
Laboratory Conditions	Temperature 5–40°C 80% Maximum Relative Humidity for temperatures up to 31°C, decreasing linearly to 50% relative humidity at 40°C. Instrument should be located in a dust-free, vibration-free environment, away from exposure to direct sunlight and direct air drafts. (Pollution Degree 2 Environment) Maximum Altitude 2000 m (6560 ft) The following factors should be minimized, if possible: <ul style="list-style-type: none"> Vibrations from the lab bench Vibrations from the floor Air Flow directed from air-condition duct work Doors being opened and closed Vibration from water flow to peltier/ sample plate Room temperature variations Magnetic impulses Variations in main air supply pressure
Laboratory Requirements	Air Bearing Gas Pressure (air or nitrogen) must be clean, dry, oil-free compressed air at 345–690 kPa gauge (50–100 psig). The dew point should be –20°C or better. Flow rate should be 25 L/min. A 1/4 NPT female connection must be provided for the AR main air supply.

AR-G2 Placement

The AR-G2 series base system consists of the Electronics Base and Instrument Base.

Select a location for the AR-G2 with adequate floor space. A solid rigid laboratory bench that is level and has a minimum depth of 76 cm (30 in), and with a width of approximately 152 cm (60 in) is recommended for the computer and electronics. A sturdy table, marble is preferred, with a minimum depth of 76 cm (30 in), and with a width of approximately 61 cm (24 in) is recommended for the AR-G2 rheometer. Please refer to the layout shown in the figure below for component placement.

AR-G2 Placement Layout

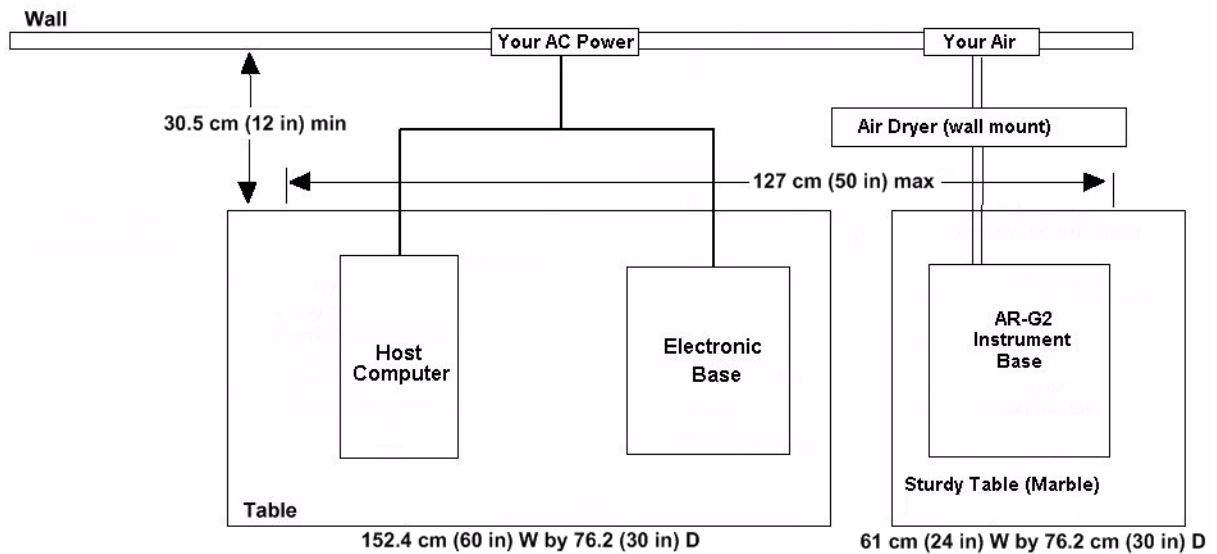

AR 2000ex, and AR1500ex Placement

The AR series base system consists of the Electronics Base and Instrument Base.

Select a location for the AR with adequate floor space and a solid rigid laboratory bench that is level has a minimum depth of 76 cm (30 in), and with a width of approximately 182 cm (72 in). Please refer to the layout shown in the figure below for component placement.

AR2000ex, and AR1500ex Placement Layout

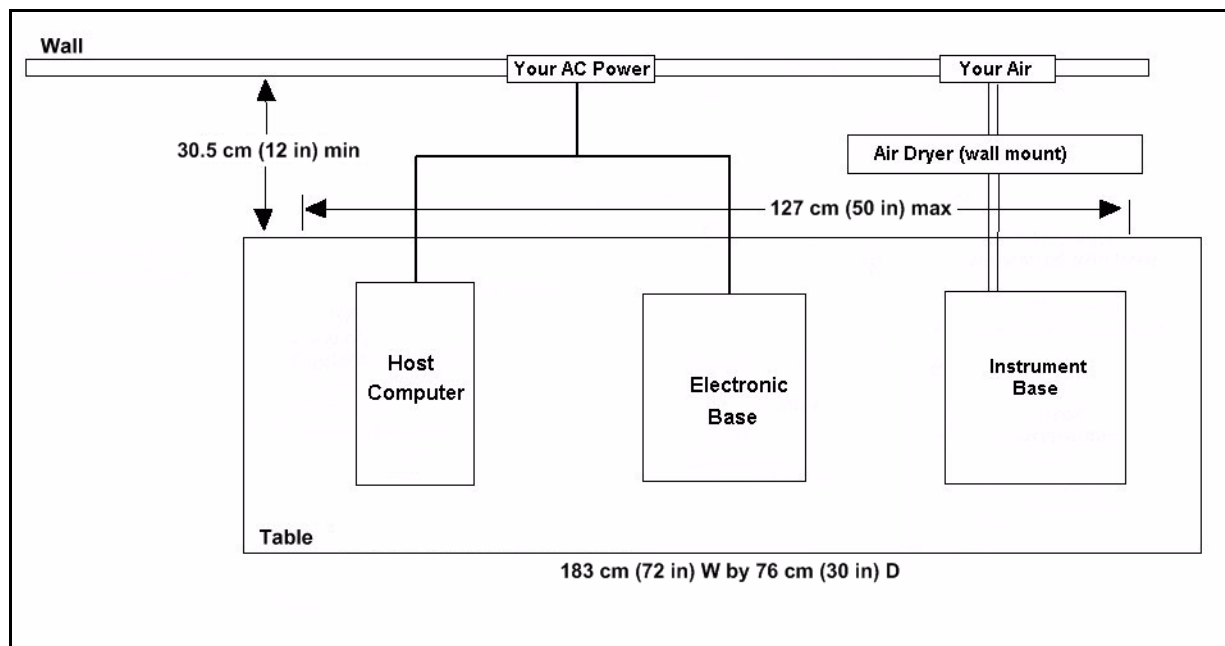

Smart Swap™ Requirements for DHR Series and AR Series Rheometers

Peltier Plate & Pelter Concentric Cylinder	Water (required for Peltier) 0.5 L/min (30.5 in ³ /min) flow if supplied from house water line; recirculating water bath supplied with rheometer is alternative.
Environmental Test Chamber (ETC)	Purge gas flow rate should be 10 L/min (610 in ³ /min) at 206–690 kPa (30–100 psi). Optional cooling liquid nitrogen at 138–207 kPa (20–30 psi). (Not available for the AR1500ex.)
Starch Pasting Cell	Water at minimum flow rate through cell of 0.2 L/min (12.2 in ³ /min). Maximum temperature 15°C. Air flow rate should be 1 L/min (61 in ³ /min) at 138 kPa (20 psi).
Upper Heated Plate (UHP) Cooling Control	See below.
AR-G2/AR 2000ex ETC Viewer	Compressed air cooling must be clean, dry and oil-free at 206–690 kPa gauge (30–100 psig). Flow rate 15 L/min (915 in ³ /min)
Pressure Cell	Compressed inert gas tank up to 13.8 MPa gauge (2000 psig) with an appropriate regulator. (Not available for the AR1500ex.)
Electrically Heated Plates	Purge flow of 5 L/min (305 in ³ /min) inert gas. Motor cooling gas flow of 10 L/min for temperatures above 250°C. Optional controlled cooling with GCA (see the next page).
Asphalt Submersion Cell	Full system integration requires a Julabo FP35-HE (See below) fluid circulator fitted with TA Instruments firmware.
UV Light Guide	If supplied without TA light source, a source with 5-mm light guide is required.
UVLED	The Peltier Plate (above) circulation fluid should not be chilled below ambient.
Small Angle Light-Scattering	As per Peltier Plate (above) and circulation fluid temperature should not be below ambient.

Upper Heated Plate Requirements

The cooling rate and minimum temperature will depend on the source of cooling.

Standard Cooling Option (For temperatures above 10°C)	Requires circulation fluid by continuous supply from mains tap or from supplied fluid circulator. For fluid cooling the supply should be 5°C below the minimum required temperature at a minimum flow rate through the system of 0.2 L/min. Air: Compressed air 1 L/min at 206–690 kPa (30–100 psi).
Low Temperature Cooling Option with Circulator (For temperatures below 10°C)	Requires Circulator and appropriate circulation fluid such as silicone fluid. CANNOT USE WATER AS CIRCULATION FLUID WITH THIS CONFIGURATION. The supply should be 5°C below the minimum required temperature at a minimum flow rate through the system of 0.2 L/min (12.2 in ³ /min)
Low Temp/Vortex Cooling Option with Vortex Cooler	Air: Clean, dry, oil-free compressed air 200 L/min at 552–690 kPa gauge (80–100 psig). The dew point should be –30°C or better.

Gas Cooling Accessory (GCA) for Use with Electrically Heated Plates

Dimension	Width (diameter): Dewar 46 cm (18 in), Feet 79 cm (31 in), Height: 107 cm (42 in)
Weight	46 kg (101 lbs.) – empty; 87 kg (191 lbs) – full
Power Requirements	120 Vac at 0.9 kW, 47-63 Hz or TA transformer, P/N 546153.901 for 220 VAC environments.
Laboratory Requirements	GCA is refilled by connecting to a 160 L liquid nitrogen tank with pressure of 150–170 kPa gauge (22–25 psig)

Circulator (Julabo FP35-HE)

(Used with Asphalt Submersion Cell. Must be placed on floor.)

Dimensions	Width 30.5 cm (12 in), Height 64 cm (25 in), Depth 43 cm (17 in)
Weight	34 kg (74 lbs.)
Power Requirements	115 VAC @ 60 Hz (14 Amp); 230 VAC @ 50 Hz (12 Amp) 15 Amp with receptacle and plug
Laboratory Requirements	Same general environmental requirements as rheometer.
Fluid Requirements	Distilled or deionized water.

Liquid Nitrogen Dewar

(Used with the AR Rheometers ETC accessory for sub-ambient operation.)

Dimensions	Width 46 cm (18 in), Height 128 cm (50 in) (Unit designed to sit on floor.)
Weight	48 kg (106 lbs) - Empty 96 kg (211 lbs) - Full
Power Requirements	None
Laboratory Requirements	Same general environmental requirements as rheometer. Dewar is refilled by connecting to a 160 liter nitrogen tank with a pressure of 150–170 kPa gauge (22–25 psig). A transfer hose is required for filling the Dewar and is not supplied by TA Instruments. The diameter of the standard 160 L external LN ₂ tank is approximately 51 cm (20 in). Allowance should be made for the tank to stand at the LN ₂ Controller (left) end of the table.

ARES-G2 Rheometer / RSA-G2 DMA

The following table lists requirements for the ARES-G2 and RSA-G2. The specifications below apply to both instruments, unless noted otherwise.

Dimensions	<p>Test Station: Width 46 cm (18 in), Depth 56 cm (22 in), Height 104 cm (39.37 in)</p> <p>Power Supply Enclosure: Width 32 cm (12.5 in); Depth 48 cm (19 in); Height 34 cm (13.5 in)</p> <p>Environmental Supply Enclosure: Width 32 cm (12.5 in); Depth 48 cm (19 in); Height 11 cm (4.5 in)</p>
Weight ARES-G2 RSA-G2	<p>104.5 kg (<230 lbs)</p> <p>95.3 kg (<210 lbs)</p>
Power Requirements	<p>Line voltage connects into power supply enclosure via 8 ft (2.44 meter) power cable</p> <p>If Forced Convection Oven¹:</p> <p>180–264 VAC, 47–63 Hz, and single phase Dedicated 20-amp outlet</p> <p>If APS, Peltier Plate, or Sealed Bath and NO FCO.</p> <p>90–264 VAC, 47–63 Hz, and single phase Dedicated 15-amp outlet</p>
Laboratory Conditions	<p>Temperature 15–35°C</p> <p>Relative Humidity <80% non-condensing</p> <p>Instrument should be located in a dust-free, vibration-free environment, away from exposure to direct sunlight and drafts. (Pollution Degree 2 Environment)</p> <p>Maximum Altitude 2000 m (6560 ft)</p>
Laboratory Requirements	<p>The air supply should be 100 psig (.69 MPa) and able to sustain a flow of either 4 scfm (115 L/min) for units without an FCO or 9.5 scfm (270 L/min) for units with an FCO.</p> <p>Air must be clean, dry, oil-free instrument quality. The dew point of the supplied air should be –10°C or lower. TA Instruments recommends purchasing the air dryer to account for the necessary dew point and air quality.</p> <p>The suggested minimum work table size is 87 cm x 165 cm (34 in x 65 in).</p> <p>Access of 61 cm (24 in) behind the table is recommended for service and maintenance.</p>

- The image below shows the L6-20, 220 VAC plug provided with the FCO for US customers. Customers should supply an L6-20 outlet.



For instruments with an FCO requiring N₂ gas for the sample medium, set the N₂ gas supply pressure to 70–125 psi (0.48–0.86 MPa) with a flow rate of 100 L/min (3.5 scfm). In this situation, air flow can be reduced to 170 L/min (6 scfm).

ARES-G2 / RSA-G2 Placement

The ARES-G2 / RSA-G2 base system consists of the Test Station, Power Supply Enclosure with at least one Environmental Supply Enclosures stacked on top, and the Host Computer.

Select a location for the system with adequate floor space and a solid, rigid laboratory bench that is level. The bench should be able to support at least 182 kg (400 lbs) of equipment and have a minimum depth of 76 cm (30 in). Width will vary depending on how the instrument is placed.

The Test Station must be within 2.44 m (8 ft) of the outlet of the air dryer assembly.

The Power and Environmental enclosures can be placed on the floor. A 2.44 m (8 ft) umbilical cord connects the rear panels between the Test Station and Power enclosure. The Power enclosure must be within 2.44 m (8 ft) of the line voltage outlet.

The Forced Convection Oven (FCO) may be placed on either side of the Test Station tower depending on placement. Leave at least 41 cm (16 in) on the side of the Test Station the oven is mounted to allow the oven to be swung open. The FCO must not come within 6 inches of any wall or flammable surface when it is fully open. The rear of the oven must be within 1.8 m (6 ft) from the rear panel of the Environmental enclosure in order to connect the cable between the oven and enclosure.

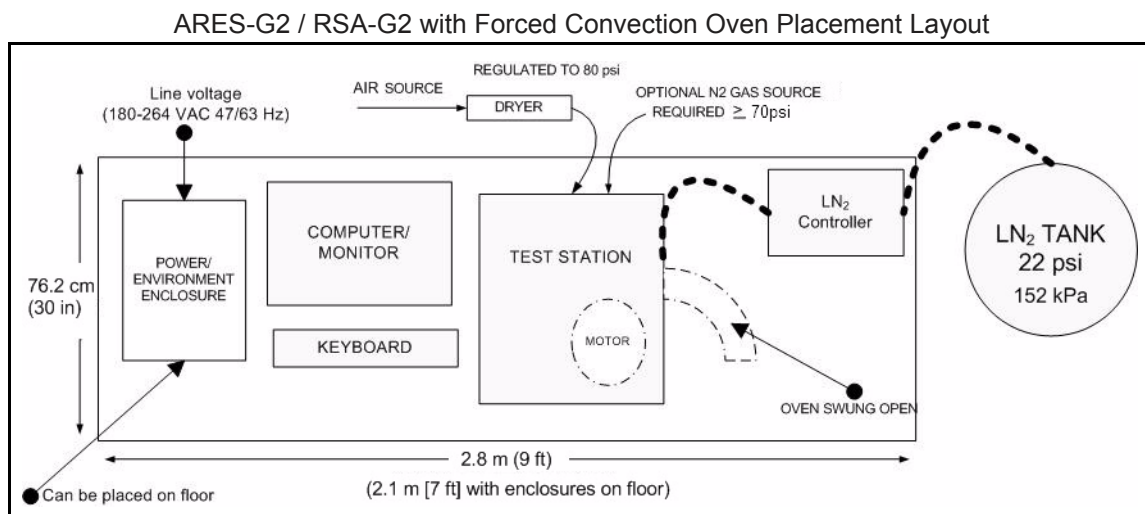

Optional N₂ gas source is for temperatures above room temperature only. LN₂ controller is for use to reach sub-ambient temperatures.

The LN₂ Controller is placed about 0.6 m (2 ft) from the side of the oven. The Liquid Nitrogen tank should be near the inlet side of the LN₂ Controller. A 0.9 m (3 ft) hose is provided to connect from the tank into the LN₂ Controller.

The Chiller, for use with the Forced Convection Oven, needs to be placed on the floor near the rear port of the oven. A flexible transfer line is provided to connect from the outlet of the Chiller to the inlet of the oven.

Circulators should be placed on the floor near the ARES-G2 Test Station. Included with the instrument is 1.8 m (6 ft) of hose to connect from the circulator to the Bath or Peltier mounted on the Test Station.

ARES-G2 with Peltier or Bath Placement Layout

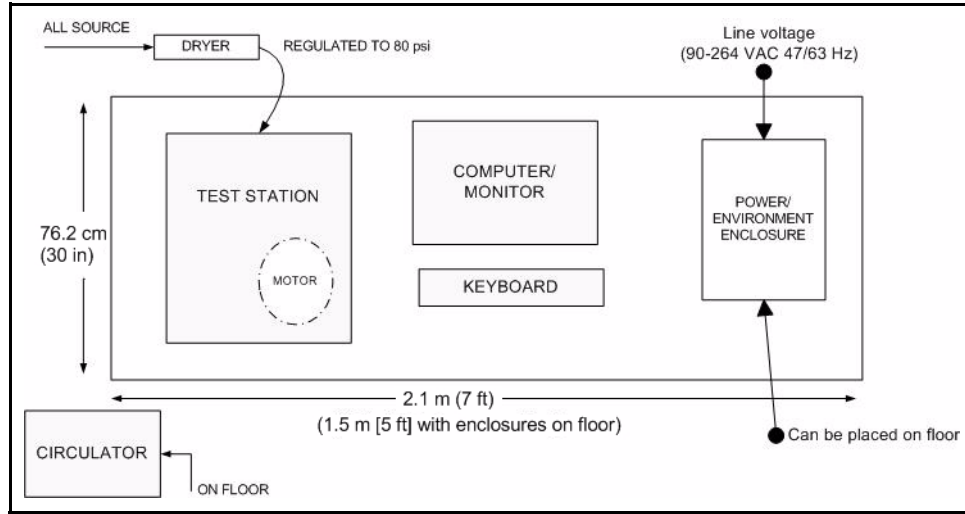

CAUTION: The test station must be located on a rigid and reasonably level surface to prevent erroneous sample results from vibrations due to table or floor movements, outside noise or people hitting the table or the instrument. For the most sensitive measurements we recommend placing the instrument on a separate marble table.

Miscellaneous Rheology Accessories

Liquid Nitrogen Controller

(Used with ARES-G2 and RSA-G2. Optional for Forced Convection Oven.)

Dimensions	Width 28 cm (11 in), Height 58 cm (23 in)
Weight	14 kg (30 lbs) - Empty 15 kg (33.5 lbs) - Full
Power Requirements	Supplied by FCO Controller.
Laboratory Requirements	<p>Same general environmental requirements as main instrument (Test Station). The FCO can be mounted on either side of the test station tower. The LN₂ Controller should be placed on the same side as the FCO.</p> <p>Requires a user-supplied 160 liter (or larger) Liquid Nitrogen tank with a pressure of 95–150 kPa gauge (14–22 psig) or an in-house supply with a ½-inch, 45° flared fitting, isolated by a shutoff valve. LN₂ pressure in excess of 207 kPa gauge (30 psig) may cause damage to the LN₂ Controller. Most in-house supplies of the LN₂ tends to contain a certain volume of gaseous nitrogen (N₂), which occurs due to heating in the supply line (near the LN₂ Controller) before delivery to the LN₂ Controller. Keeping the supply line short, and providing adequate insulation will minimize gaseous Nitrogen build-up in the supply line. Failure to observe this caution may cause the LN₂ Controller to malfunction frequently.</p> <p>A 0.9 m (3-ft) supply hose is provided for connection between supply tank and LN₂ Controller.</p>

Air Dryer

(Recommended for use with ARES-G2 and RSA-G2.)

Dimensions	Width 36 cm (14 in), Height 27 cm (10.5 in), Depth 10.5 cm (4 in)
Weight	3.2 kg (7 lbs)
Power Requirements	None
Laboratory Requirements	<p>Same general environmental requirements as rheometer.</p> <p>Inlet air: 0.7–0.9 MPa (100–130 psig); air temperature $\simeq 20^{\circ}\text{C}$</p> <p>The air dryer MUST be mounted upright on the wall within 183 to 244 cm (6 to 8 feet) of the air source. The center holes of its two mounting brackets are 22.3 cm (8.8 in) apart. The air source into the dryer should be oil-less compressed air.</p> <p>The customer should provide a means to connect to a 3/8" NPT male connector on the inlet hose of the air dryer (provided by TA Instruments). The customer should provide a gauge to monitor the 0.7 MPa gauge (100 psig) source of clean dry air into the air dryer. The air supply from the air dryer must be regulated to provide 0.55–0.6 MPa gauge (80–90 psig) into the test station. The flow rate will vary depending on type of environmental system.</p> <p>Air dryers are designed to remove moisture from the air. They are not designed to remove water from the air. If you have excessive moisture levels that result in the immediate condensation into water, the membrane type air dryer may get over saturated and cause damage. Your maintenance personnel should install an external 'Water Trap', before feeding the air into the Air Dryer.</p> <p>Inlet air should be at Relative Humidity of 70% or less, at RT with particle size of 5 microns (0.0002 in) or less.</p> <p>An 2.44 m (8-ft) hose is provided for connection from outlet of air dryer regulator to the rear of the test station.</p>



CAUTION: The air into the instrument must meet the above requirements or damage to a major component within the instrument may occur. Such damage is NOT covered by Warranty, written or implied.

Gas Chiller

This Gas Chiller is used in conjunction with Forced Convection Oven for the ARES-G2 and RSA-G2.

The Gas Chiller must be purchased directly through:

Brooks Automation

Model: Polycold PGC-152 AC (model number 700179-01)

Website: www.brooks.com

Phone: 707-769-7000

Dimensions	Width 74 cm (29 in), Height 127 cm (50 in), Depth 51 cm (20 in)
Weight	68 kg (150 lbs.)
Power Requirements	197 to 253 VAC @ 60 Hz; 180 to 229 VAC @ 50 Hz 15 Amp with receptacle and plug
Laboratory Requirements	Same general environmental requirements as rheometer Fitting for ¼-inch ID hose Air/N2 supply 0.55 kPa gauge (80 psig) to support a flow at 156 L/min Inlet air temperature no higher than 25°C (7°F) Gas Chiller is designed to be on the left side or rear of the ARES-G2 or RSA-G2, on the floor.

Circulator (Julabo FP35-MC)

(Used with the Sealed Bath with the ARES-G2. Must be placed on floor.)

Dimensions	Width 30.5 cm (12 in), Height 64 cm (25 in), Depth 43 cm (17 in)
Weight	34 kg (74 lbs)
Power Requirements	115 VAC @ 60 Hz (14 Amp); 230 VAC @ 50 Hz (12 Amp) 15 Amp with receptacle and plug
Laboratory Requirements	Same general environmental requirements as rheometer
Fluid Requirements	Recommended 50/50 mixture of distilled or dionized water/laboratory-grade ethylene-glycol for a circulator temperature range of -5 to 105°C.



CAUTION: Only laboratory-grade ethylene glycol should be used in circulators.

Additional Circulators

(Used with the Peltier Plate with the ARES-G2. Must be placed on floor.)

ThermoCube Peltier Cooling Circulator Model 10-300

Dimensions	Width 28 cm (11 in), Height 32.4 cm (12.75 in), Depth 32.4 cm (12.75 in)
Weight	12.7 kg (28 lbs)
Operating Range	-5 to + 65°C
Power Requirements	115–230 VAC @ 50/60 Hz (3.5 Amp) 15 Amp with receptacle and plug
Laboratory Requirements	Same general environmental requirements as rheometer.
Fluid Requirements	80/20 water/alcohol mixture (recommended)

TA Instruments Offices

For information on our latest products, contact information, and more, see our web site at:

<http://www.tainstruments.com>

TA Instruments — Waters LLC
Corporate Headquarters
159 Lukens Drive
New Castle, DE 19720
USA

Telephone: 302-427-4000
Fax: 302-427-4001
Email: info@tainstruments.com

